

# WQ Series

Engineered Water Quality Solutions

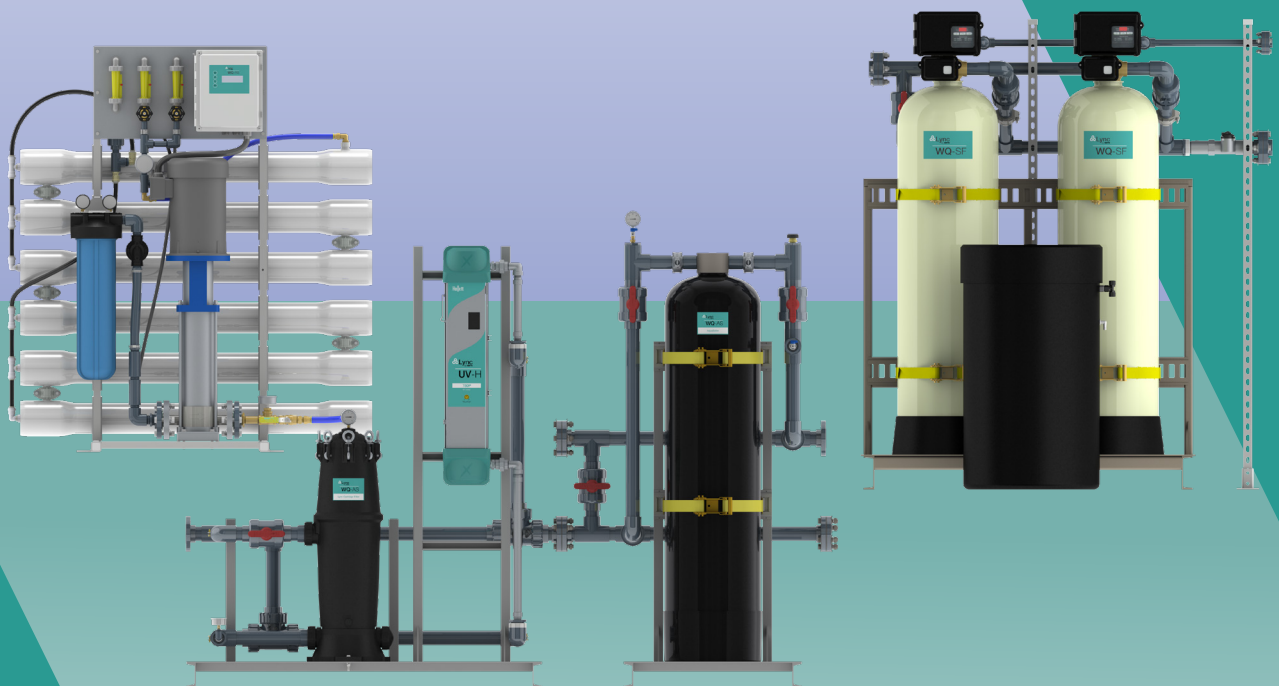

[Lyncbywatts.com](http://Lyncbywatts.com)

 **Lync**<sup>®</sup>  
by **WATTS**

# Complete and Effective Water Quality Solutions

Lync's WQ Series consists of unique solutions that are engineered by water quality experts to address water quality issues that impact water heaters and plumbing systems.

Water conditions, such as minerals, sediments, chemicals, and microorganisms, can severely impede the performance, reliability, and lifespan of the water heating system. Poor water quality can lead to many negative consequences, including:

- Increased risk of pathogen growth
- Deteriorating water heater efficiency
- Higher maintenance and operational costs
- More frequent component replacements
- Worsening environmental impact

## Fully Engineered Water Treatment and Water Condition Solutions

**WQ-AS** integrates scale prevention, sediment filtration, and UV disinfection in a three-stage process that thoroughly mitigates the risks of water-borne pathogens, including Legionella, by reducing scale and biofilm build-up without the use of chemicals for greater energy savings, longer equipment lifespan, and reduced maintenance time.

**WQ-SF** is a sodium regenerated water softener solution that addresses hard water issues. It reduces scale inside the plumbing system and spot formation on the outside for improved efficiency and longevity of the system, and it can reduce the consumption of soap and cleaning products by up to 50%.

**WQ-RS** utilizes the natural process of reverse osmosis to effectively purify the water for a variety of purposes to provide safe, clean water virtually free of pathogens, toxic metals and corrosive ions.

### All Lync's WQ solutions are:

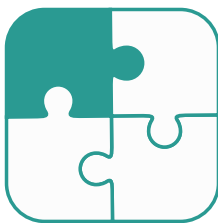

**Pre-Assembled**  
to simplify installation



**Configurable**  
to fit into any project



**Single-Source Origin**  
to solve issues quickly

# Save Time, Lower Costs and Improve Water Quality



## Improve Water Quality

Mitigates the risks of water-borne pathogens, including Legionella

- Highly effective, multi-barrier technologies keep building occupants safe by mitigating risks of Legionella and other harmful waterborne pathogens
- Scale preventing features reduce corrosion and extend life of components



## Save Time

Easy Planning, Simpler Installation and Quick Support

- Compact design and known specs for easy planning and reduced timelines
- Pre-assembled to make installation simpler and quicker and limit delays
- Designed and built by the manufacturer means one single point of support



## Reduce Costs

Less Downtime and Maintenance and Improved System Performance

- Small footprint to easily drop into plans for reduced downtime and install costs
- Reduction of water impurities for greater heater system efficiency and lifespan
- Water treatment technologies with minimal maintenance required



## Be More Sustainable

Lessened Negative Impact on Environment

- Environmentally safe anti-scale media that is easily disposed of (WQ-AS)
- No chemical byproducts from disinfection process (WQ-AS)
- Reduced consumption of soaps and cleaning products by up to 50% (WQ-SF)

Rely on the Water Quality Experts



# WQ-AS: Multi-Barrier Protection Against Pathogens

Mitigates the risks of bacteria\* through effective anti-scale technology, sediment filtration and UV disinfection.

## Thorough Pathogen Mitigation and Anti-Scale

WQ-AS mitigates build-up of sediment and scale upon which bacteria thrive, using media assisted crystallization technology to transform dissolved hardness minerals into harmless, passive microscopic particles without using salt or harsh chemicals.

## Effective UV Disinfection with Sediment Filtration

The UV-H disinfection system is capable of 6-log reduction of bacteria\*, including Legionella, as UV light breaks down the DNA of the pathogens. An integrated sediment pre-filtration ensures the water clarity so that a germicidal dose of UV light can reach all parts of the water.

## Greater Efficiency and Lower Maintenance Costs

A reduction in scale and sediments increases the operating efficiency of the water heating system. WQ-AS operates with no backwashing, salt or chemicals, and it requires minimal maintenance and replacements.

## Non-Toxic and Environmentally Friendly

No salt or chemicals are added to the water treatment process for safer water with no change in taste or smell. The anti-scale media is environmentally friendly with no backwash cycle resulting in less water usage, and the UV disinfection process creates no byproducts.



## Key Features

- Scale mitigation with no backwashing or salt
- 6-log UV light disinfection\*
- Sediment pre-filtration (5 microns)
- 40, 70 and 100 GPM configurations
- Low-maintenance components
- Fully assembled and fastened onto steel skid



**Safer Water with  
No Added Chemicals**



**Longer System Life  
Less Maintenance**



**Energy Savings and  
Heating Efficiency**

\*Tested and validated for minimum of 6-log reduction of Legionella bacteria

# Specifications

Unit	WQAS-040-S WQAS-040-C	WQAS-070-S WQAS-070-C	WQAS-100-S WQAS-100-C
<b>Performance and Specs</b>			
Number & size of Scale Prevention Tanks	1 – 16"x65"	1 – 16"x65"	2 – 16" x 65"
Number and type of Cartridge Filtration	1-LCH-150 / 1-LCB-150-P5		
Number of UV Systems	1 – UV-H 750P	1 – UV-H 1000P	1 – UV-H 1000P
Peak Flow Rate [GPM]	40	70	100
Max Operating Pressure [PSI]	125		
Max Operating Temperature [°F]	100		
Max Hardness	30 Grains (513 ppm as CaCO3)		
Max Iron	0.3 ppm		
Total Phosphates	3 ppm or less		
Max Manganese	0.05 ppm		
Turbidity	< 5 NTU		
pH	6.5 – 8.5		
Total Dissolved Solids	1500 ppm or less		
Max Copper	1.3 ppm		
Total suspended solids	10 ppm		
Max Silica	20 ppm		
Max Ambient Temperature/Humidity	122 °F / 95% Relative Humidity (non-condensing)		
Min. UVT for 40mJ/cm <sup>2</sup> Dose / 4-20 mA Modbus connection	95%		
<b>Electrical Data<sup>1</sup></b>			
Voltage [V], Frequency [Hz]	120VAC, 50/60 Hz		
4-20 mA Modbus Connection	Available for -C models		
<b>Dimensions</b>			
<b>Linear Placement</b>			
Width [in]	110		155
Depth [in]		24	
Height [in]		81	
<b>Dimensions</b>			
<b>U-Shape Placement</b>			
Width [in]	71		99
Depth [in]		54	
Height [in]		81	
Shipping Weight [lbs]	800	830	1200

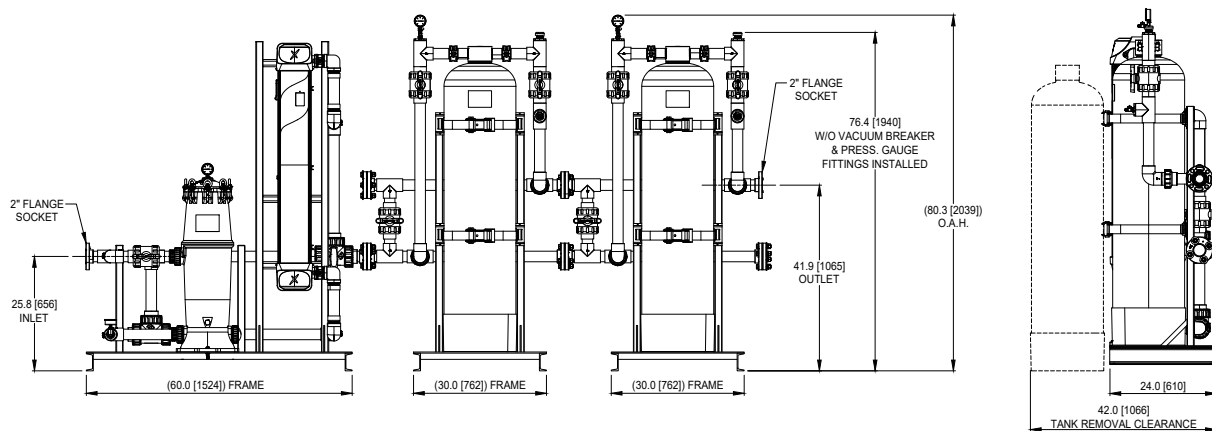

# WQ-SF: Effective and Low-Maintenance Water Softener

Effectively softens hard water by utilizing sodium and potassium to mitigate scale and improve water heater efficiency and longevity of the system.

## Reduction in Heating Costs and Longer Lifespan

WQ-SF can treat both hot and cold water to ensure that the performance and longevity benefits of softened water are reaped across the system, from water heater to plumbing system and water-using appliances.

## Configurable to Match Any Demand

Twin Alternating (TA) WQ-SF softeners come in two models. These softeners are designed to ensure an uninterrupted flow of soft water at all times. WQ-SF has also four Progressive Flow (PF) models. PF softeners are designed to ensure flexibility of operation and provide optimal efficiency at high and low flow rates.

## Metered Control Valves for Automatic Operation

System control valves with flow meters control all functions of the water softener to maximize the softener regeneration efficiency and minimize the salt consumption.

## Reduced Consumption of Soap and Other Cleaning Products

WQ-SF can reduce soap and cleaning product consumption by up to 50% by softening the water to make cleaning products more effective and improve soap lathering.



## Key Features

- Configurable tanks hold ion exchange resin
- Brine tank for regeneration solution
- Metered control valves for automatic operation
- Twin Alternating models
- Progressive Flow models
- Fully assembled and fastened onto steel skid



**Reduced Water Heating Costs**



**Prolonged Life of System Components**



**Up to 50% Reduced Soap Consumption**

# Specifications

Unit WQSF	WQSF-025-N	WQSF-050-N	WQSF-075-N	WQSF-100-N	WQSF-200-N	WQSF-300-N
<b>Performance and Specs</b>						
Twin Alternating/Progressive Flow	TA	TA	PF	PF	PF	PF
Resin Tank Quantity - Size	2 - 18" x 65"	2 - 21" x 62"	4 - 18" x 65"	4 - 21" x 62"	4 - 24" x 72"	4 - 30" x 72"
Resin (cu ft./tank)	5	7	5	7	10	15
Max Hardness Removal Capacity (grains/tank) <sup>1</sup>	150,000	210,000	150,000	210,000	300,000	450,000
Max Salt Usage (lb/tank) <sup>1</sup>	75	105	75	105	150	225
Min Hardness Removal Capacity (grains/tank) <sup>2</sup>	100,000	140,000	100,000	140,000	200,000	300,000
Min Salt Usage (lb/tank) <sup>2</sup>	30	42	30	42	60	90
Inlet/Outlet - Drain Pipe Size	2" - 1"	2" - 1"	2" - 1"	2" - 1"	4" - 1"	4" - 1"
Brine Tank Quantity - Size (in)	1 - 24D x 50H	1 - 30D x 50H	4 - 24D x 50H	4 - 30D x 50H	4 - 30D x 50H	4 - 39D x 48H
Flow Rate @ 15 psi Pressure Drop (GPM) <sup>3</sup>	57	60	216	228	296	320
Flow Rate @ 25 psi Pressure Drop (GPM) <sup>4</sup>	65	77	247	292	388	400
Backwash (GPM)	10	13	10	13	15	25
<b>Floor Space w/o Brine Tank(s) and Weights</b>						
Width (in)	75	75	135	136	149	155
Depth (in)	38	39	38	39	45	49
Height (in) <sup>5</sup>	86	86	86	86	97	103
Shipping Weight (lbs) <sup>6</sup>	2000	2200	4100	4500	5200	6200
<b>Control Valve Electrical Data</b>						
Input Voltage Phase, Frequency	100-240 VAC, Single Phase, 50/60 Hz (per control valve)					
Output Voltage, Amps	24 VDC, 2.7 A (per control valve)					

- Maximum capacity is based on 30,000 grains per cubic foot of resin when regenerated with 15 lbs of salt and minimum capacity is based on 20,000 grains per cubic foot of resin when regenerated with 6 lbs of salt.
- Flow rates listed above are based on pressure drop only. Selecting a system based on pressure drop alone does not guarantee that the system will provide adequately softened water. System selection should be based on resin quantity, capacity required, feed water analysis, and application requirements. Ask your Lync rep for more information.
- Allow a minimum of 24" above height dimension for resin loading.
- Shipping weights are estimates only (including gravel and resin bags).

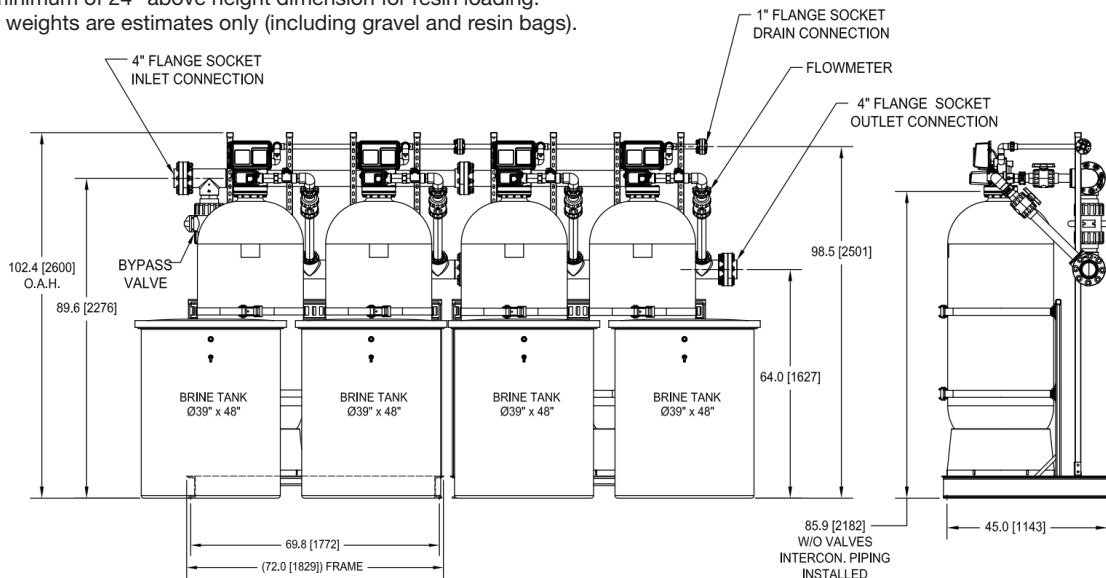

# WQ-RS: Efficient and Reliable Reverse Osmosis System

Effectively purifies water by practically eliminating the presence of dissolved solids in the water, such as salts, and toxic metals.

## Wide Application and Configurable to Match Any Water Demand

The system has a wide array of applications where purified water is critical, including municipal water treatment, laboratory use, food processing, and metal plating and finishing. The system comes in three available size configurations to meet site-specific needs.

## More Environmentally Friendly

WQ-RS offers a more sustainable water treatment solution by purifying water through the natural process of reverse osmosis rather than adding chemicals. Eliminating the use of harmful chemicals means no hazardous wastewater.

## Prolongs Life of System Components and Plumbing System

WQ-RS effectively removes corrosive ions such as chlorides and sulfates from the treated water. The result is components and piping systems that last longer and perform with greater efficiency.

## Efficiently Produces Safer, Cleaner Water

By practically eliminating the presence of toxic metals in the treated water, WQ-RS ensures cleaner, safer water which is critical in many settings, such as healthcare settings.

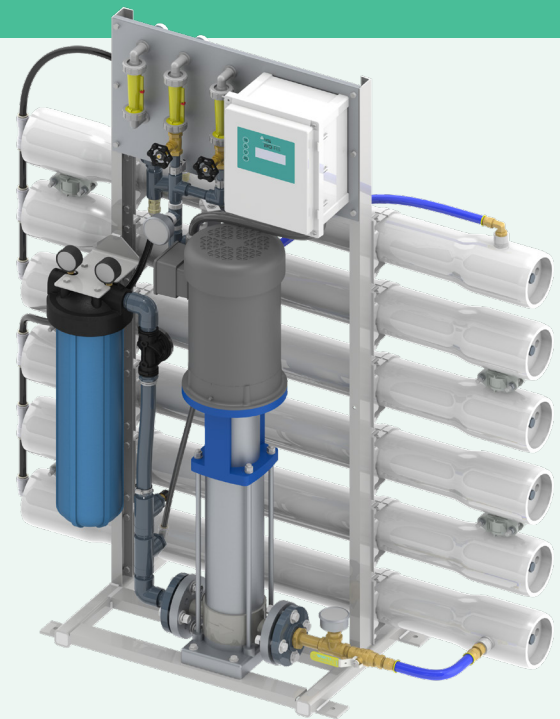

## Key Features

- Configurable: 3,600 gallons per day to 120 gallons per minute
- Minimum 95% average ionic rejection of solids
- Digital controller for easy and exact operation
- Fiberglass-reinforced plastic membrane housings
- Membrane auto flush for scale prevention
- Fully assembled and fastened onto steel skid



**Effective Ion Removal  
For Safe, Clean Water**



**Sustainable With No  
Harmful Wastewater**



**Prolonged Equipment  
And System Lifespan**

# Specifications

Model	Production Rate		Recovery	Piping Connection			Dimension L x W x H (in)	Membrane		Shipping Weight (lb)
	GPM	GPD		Feed Water	Product Water	Reject Water		Quantity	Size (in)	
WQRS-005-R	2.5	3,600	25%-75%	1"	3/4"	3/4"	51 x 18 x 57	2	4 x 40	400
WQRS-010-R	5	7,200	42%-75%	1"	3/4"	3/4"	51 x 18 x 57	4	4 x 40	600
WQRS-015-R	7.5	10,800	50%-75%	1"	3/4"	3/4"	51 x 18 x 57	6	4 x 40	800
WQRS-030-R	15	21,600	50%-75%	2"	1 1/2"	1"	108 x 42 x 72	3	8 x 40	1600
WQRS-060-R	30	43,200	50%-75%	2"	1 1/2"	1"	108 x 42 x 72	6	8 x 40	2200
WQRS-090-R	60	86,400	65%-75%	2 1/2"	2"	1 1/2"	196 x 41 x 79	12	8 x 40	2800
WQRS-180-R	120	172,800	65%-75%	3"	2 1/2"	1 1/2"	196 x 41 x 79	24	8 x 40	3800

## Notes

For all other guideline information please contact your Lync representative. Published maximum production rates are based on a feed water of 77°F, SDI of less than 3, 1000 ppm TDS, and pH 8. Individual membrane productivity may vary ( $\pm 15\%$ ). May be operated on other feed waters with reduced capacity. Percent rejection is based on membrane manufacturer's specifications; overall system percent rejection may be less.

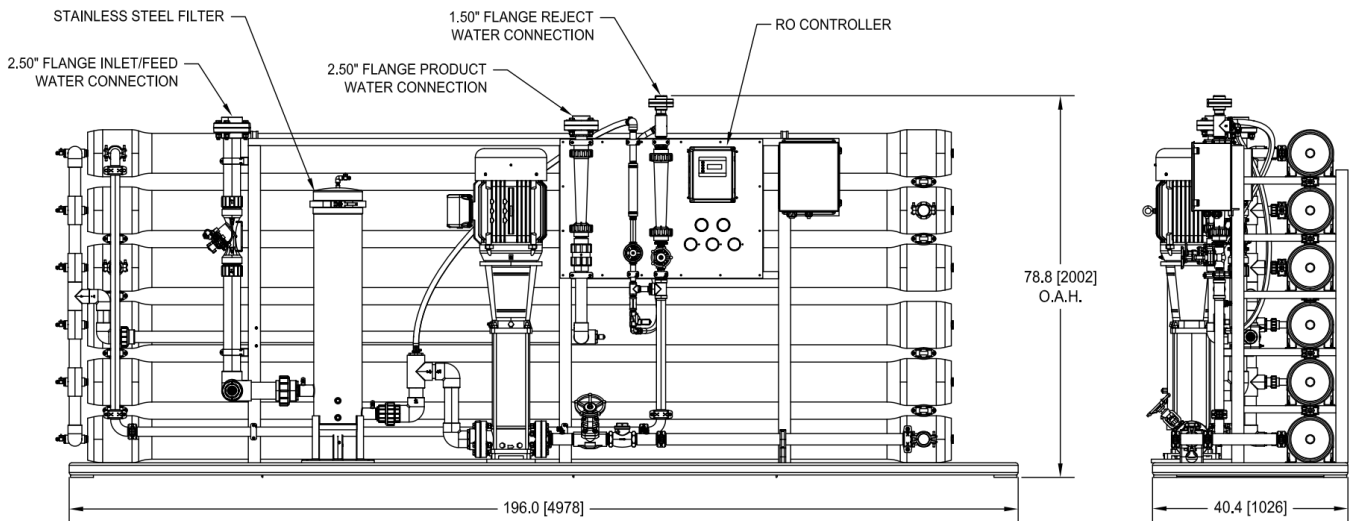

# More Solutions from Lync



## Aegis

- CO<sub>2</sub> Heat Pump Water Heaters
- Air, water, or air with water source recovery
- Wide ambient temperature operation:
  - Aegis A from -4°F (-20°C) to 113°F (45°C)
  - Aegis W from 18°F (-8°C) to 86°F (30°C)
- Coefficient of Performance of 5.0 or higher
- Non-toxic and non-flammable refrigerant
- Remote control via building automation system

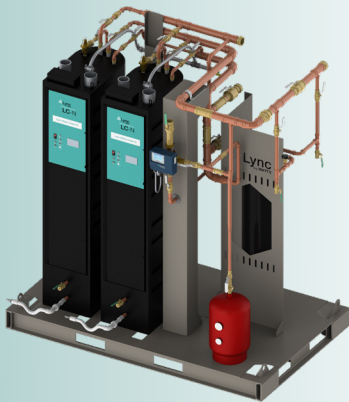

## LC-N

- Engineered, pre-assembled domestic hot water systems
- High efficiency water heating, digital mixing, anti-scale
- Built-in redundancy with a compact footprint
- Configurable: 399-1200 MBH



## Electric Water Heaters

- Storage water heaters (250-500 gallons)
- Outdoor installation (optional coating required)
- Wall-mounted, compact electric water heater
- Backup, booster, or recirculation for heat pumps



## Storage Tanks and Accessories

- Outdoor storage tanks up to 1000 gallons
- Environmentally friendly scale control systems
- Safe and precise digital mixing valve solutions

# Engage™ with Us

## Complete design development and project execution with one convenient point of contact.



Finding the right, cost-effective system for your building can be a long, confusing, overwhelming process. With so many moving parts, it is often difficult to zero in on what exactly your building needs are in terms of energy efficiency, water safety, regulatory compliance, and water technologies.

With Lync's Engage, you get a planner, a designer and a single point of sourcing and responsibility to develop and execute your project tailored to your needs and circumstances.

As experts in heating, hot water, and water quality products and systems, we leverage decades of industry knowledge, our vast network of connections and direct insider access to a broad product portfolio to give you the best plan of action specifically tailored to your site.



## Project Capabilities

Domestic Hot Water Systems • Hydronic Hot Water Systems • Water Quality Systems • More

For more info, visit [lyncbywatts.com](http://lyncbywatts.com) or email us at [engage@lyncbywatts.com](mailto:engage@lyncbywatts.com).

# Complete Engineered System Solutions

Superior Safety. Maximum Efficiency. Improved Water Quality.



Lync combines advanced technologies and innovative design with industry-leading manufacturing expertise to deliver complete, cost-effective commercial water technology system solutions from a single source.

Our fully assembled, integrated solutions provide your building with maximum efficiency, superior safety and improved water quality while minimizing planning, design and installation time to reduce costs and increase your return on investment.

[Lyncbywatts.com](http://Lyncbywatts.com)



Engineered Solutions

Fort Worth, TX • (817) 335-9531 • [lyncbywatts.com](http://lyncbywatts.com)

© 2026 Lync