

**Symbols**

- Pressure Relief Valve
- Balance Valve
- Union
- Air Vent
- Pump
- Backflow Preventer
- Strainer
- Flexible Fitting
- Mixing Valve
- Ball Valve
- Expansion Vessel
- Check Valve
- Injection Tee
- Motorized Valve

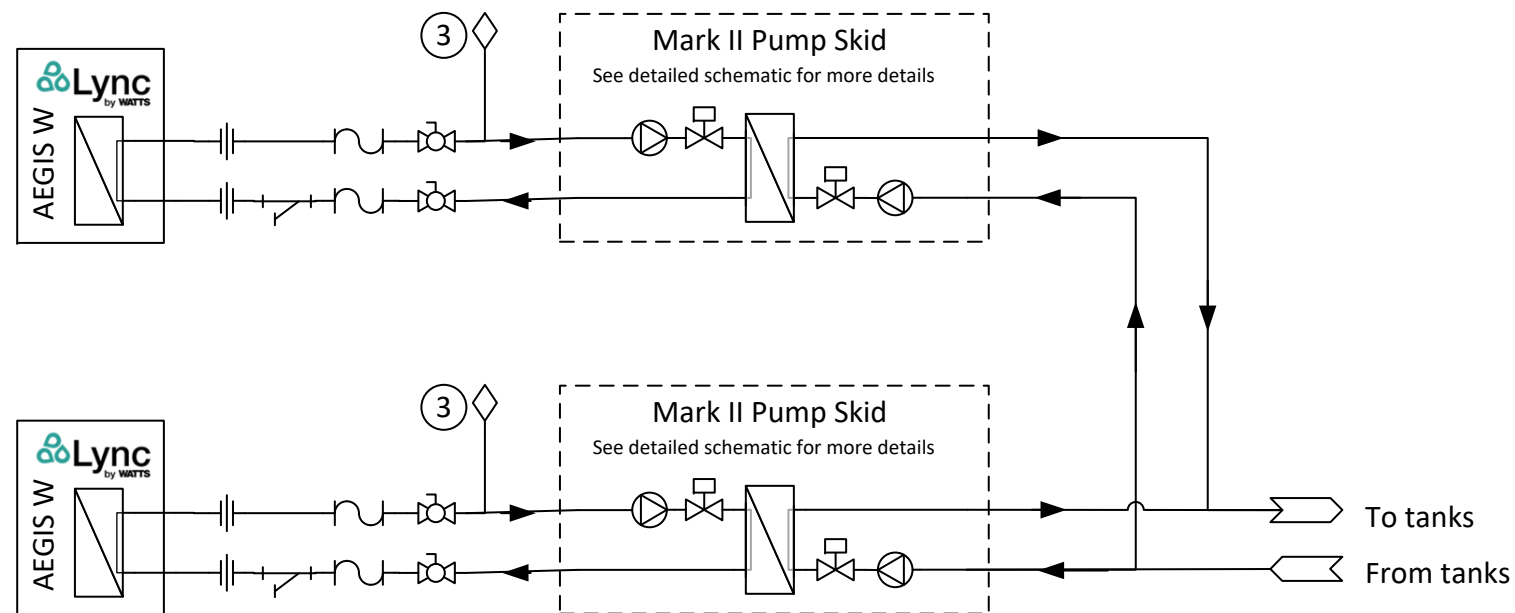

**Notes:**

- 1) Final pump skid design subject to change.
- 2) Pipe flow velocity not to exceed 2 ft./sec. Use 1 1/4" copper pipe for Aegis 250 and 350 and 1 1/2" copper pipe Aegis 500 between heat pumps and skids.
- 3) Air vent must be installed at the highest point in the plumbing. Manual shut off valve recommended below air vent.
- 4) PRV must be piped within 18" of floor or per plumbing code on each pump skid.

|                           |          |  |          |
|---------------------------|----------|--|----------|
|                           |          | Fort Worth, TX 76134<br>Blauvelt, NY 10913 |          |
| <b>MIID 2 Aegis Water</b> |          |  |          |
| DRWN. BY                  | DATE     | DWG. NO:                                   | REV.     |
| BJC                       | 03/27/23 | SD-L-1314                                  | <b>A</b> |
| Page 1 of 46              |          |  |          |