

Electronic Controller User Manual

Aegis Sequencer



Disclaimer:

The information contained in this document is subject to change without notice from Watts Heating and Hot Water Solutions LLC dba Lync by Watts ("Lync"). Lync makes no warranty of any kind with respect to this material, including, but not limited to, implied warranties of merchantability and fitness for a particular application. Some states do not allow the exclusion or limitation of incidental or consequential damages, so the above limitation may not apply. Lync is not liable for errors appearing in this document, not for incidental or consequential damages occurring in connection with the furnishing, performance, or use of these materials.

Engineered Solutions

CONTENTS

1. INTRODUCTION..... 3

2. SYSTEM COMPOSITION..... 3

 2.1. Electrical Connections 3

 2.2. Ethernet Network 4

 2.3. Sequence of Operation..... 5

3. SETUP 5

4. USER INTERFACE..... 8

 4.1. Electrical Panel User Terminal 8

 4.2. Main Screen and Control Logic 8

 4.2.1. Anti-Legionella Management..... 9

 4.2.2. Secondary Pump Management 9

 4.3. User Settings 10

 4.3.1. On/Off 10

 4.3.2. Set 11

 4.3.3. Anti-Legionella 11

 4.3.4. Info..... 12

 4.3.5. Unit Info Menu..... 13

5. MAIN MENU..... 14

 5.1. Menu Loops and Layout 15

 5.1.1. Menu A: Input/Output 15

 5.1.2. Menu B: Thermoregulation 16

 5.1.3. Menu C: Manager Parameters 16

 5.1.4. Menu D: Clients Parameters 17

 5.1.5. Menu E: User Settings 17

6. ALARM MANAGEMENT 22

 6.1. Alarm Screens and LED 22

 6.2. Alarms Log..... 23

7. REMOTE INTERFACE 24

APPENDIX A – PLANT DRAWINGS AND SENSOR LOCATIONS..... 25

 A.1. Plants with Two Units 25

 A.2. Plants with Three Units..... 26

 A.3. Plants with Four Units..... 27

 A.4. Plants with Five Units 28

APPENDIX B - WIRING CONNECTIONS..... 29

APPENDIX C - PART NUMBERS 31

APPENDIX D – BAS COMMUNICATION POINTS 32

1. INTRODUCTION

The Aegis Sequencer controller can be used in systems where several Aegis heat pumps are installed parallel to each other, using the same tank system, and requiring a common control point. The system can include up to six units, regardless of model size, and can manage a secondary side water pump. The device can detect the thermal demand of the tanks and activate the appropriate number of units.

The required number of units is determined by temperature probes located in the tanks. The probes determine how much power, and how many steps are activated, which will detect water temperature stratification in the tanks.

The settings can be changed via the user interface (graphic display) or BMS.

2. SYSTEM COMPOSITION

The system consists of the Aegis Sequencer electrical panel equipped with water temperature probes to be placed in the water tanks (see below), as well as digital I/O to dialogue with third-party building automation systems. An ethernet connection between the Sequencer and the heat pumps is required.

The Aegis Sequencer ships with the following items:

- Sequencer
- (9) 10 k Ω temperature sensors
- A packet containing the user manual and electrical schematics
- Enclosure key, tied to the power switch



2.1. Electrical Connections

During installation, refer to the wiring diagram in Appendix B.

The probes should be positioned as follows:

- BT1 probe: in the coldest point, i.e. the lower part of the storage group (return circuit side towards units), or where maximum load set point management of storage system happens
- BT2 probe: in the hottest point, i.e. the upper part of group (delivery circuit towards secondary)
- BT3 probe (secondary side pump management): at outlet of the exchanger, wired to the unit
- S2 - S6 probes (power step requirement probes): to be distributed evenly between the tanks A total of N+1 sensors will be required, where N is the number of heat pumps
- BTL probe (anti-Legionella probe): at the inlet of the heat exchanger

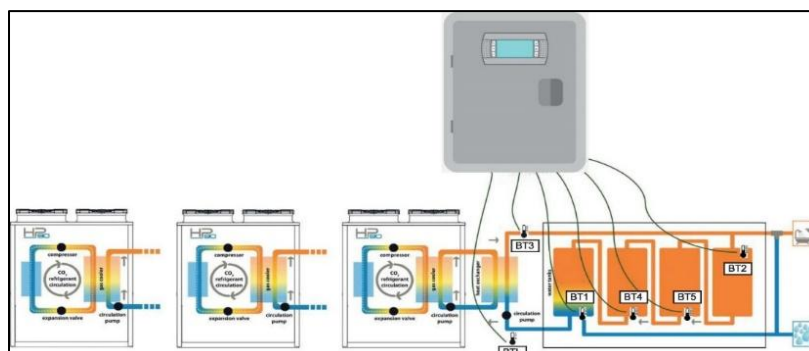

2.2. Ethernet Network

The Aegis units (clients) connect to the Aegis Sequencer cascade controller (manager), via an Ethernet network with a star structure. Modbus TCP communication protocol is used between the manager and the clients.

The network switch is pre-installed inside the electrical panel. By connecting the switch to the local network, the end user can access the unit's web server from a local network, or read the system's information via BMS.

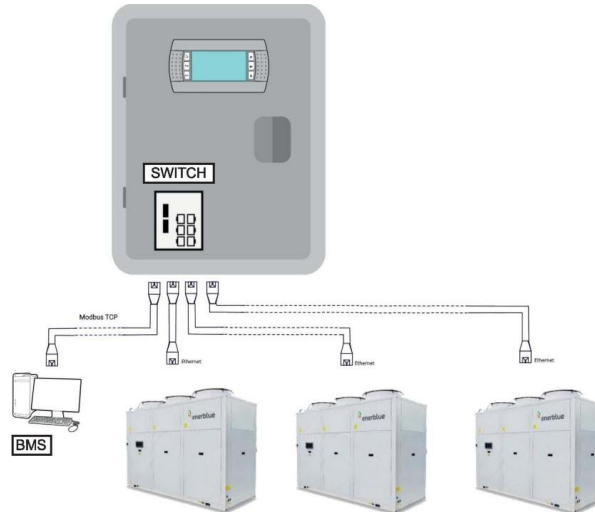

Both the individual Aegis units and the Aegis Sequencer must be set up with a consistent IP address (i.e. part of the same class network/subnet). Refer to the Aegis control manual, L-OMM-013 Lync Aegis Electronic Controller Manual in section 8.12.5. MENU - Et Ethernet, for details on how to set the network address on each unit. The addresses assigned to the individual units must be configured in the Manager in Menu D: Client parameters.

In the Service - Service Setting menu, for each heat pump it is necessary to set the parameters according to the image below:

SERVICE

SERVICE SETTING DEFROST CONFIG POLYNOMIAL MODBUS CONTROL PANEL

NOTE:

The configuration of these parameters must be performed by **QUALIFIED PERSONELL ONLY**.
Incorrect changes may cause a malfunction of the Heat Pump.

REMOTE CONTROL

Address	Label	Name	Value	Unit
17547	RC01	Remote control enable	ON	
17548	RC02	Main ON/OFF	OFF	
17549	RC03	Thermal regulation by ID or supervision	Supervision	
16557	RC04	Maximum duration before reset remote control (0=disabled)	0	min

2.3. Sequence of Operation

Temperature control is only active when the system is turned on. When the system is turned off (from the keyboard, BMS, digital contact, etc.), the control panel only receives data from the units and displays any anomalies (e.g. offline units).

The Aegis Sequencer activates the client units in order based on the value of the temperature probes positioned in the storage system. The BT1 and BT2 probes, which have two independent set points, function as follows:

- Probe BT1: If the set point for the BT1 probe is reached, other units can be activated, unless the set point for the BT2 probe is reached.
- Probe BT2: If the set point for the BT2 probe is not reached, a heat pump will be forced on, even if set point on probe BT1 is reached.
- Probes S2 - S6: The additional probes are associated with distinct points and differentials, calculated by adding an offset to the set referred to as BTL. Except for the management associated with the BT1 and BT2 probes, each unsatisfied set will raise the request for an additional unit to activate.

See **Section 4.3, User Menu**, for more information on menu settings.

3. SETUP

1. Provide 120V power to the unit at the main switch on the top-right of the cabinet. Electrical protection and a disconnect switch must be field-provided by a licensed electrician as per local code requirements.
2. Use the 10 k Ω temperature probes provided to make all connections needed inside of your tank system, as follows. The number of temperature probes needed is equal to the number of heat pump units installed, plus one (see *Appendix B: Wiring Connections*).
 - BT1: the coldest point of the tank system connects to terminal 1 and GRND2
 - BT2: the hottest point of the tank system connects to terminal 2 and GRND2
 - BT3: the outlet of the heat exchanger connects to terminal 3 and GRND2
 - BTL: the inlet of the heat exchanger connects to terminal 4 and GRND2
 - S2 - S6 : spread evenly throughout the tank system and all connect into the consecutive terminals and GRND2s
3. For installations with a dedicated heat exchanger and primary pump for each heat pump, the pumps must be wired into the individual heat pumps. (See *L-OMM-013*)
If only one pump and heat exchanger is being used for all heat pump units, the single primary pump must now be wired into the Sequencer. The pump should be connected into terminals 103 and 104. (see *Appendix B Wiring: Connections*).

Please note: This is not a recommended application as the Lync heat exchanger modules are only designed to work with a single heat pump.

4. Each unit must be connected into the ethernet switch inside of the Sequencer. Remote controls or BMS are also accessed through the ethernet switch.
 - The first port is used to connect the ethernet switch and the control board of the Sequencer. This connection is factory-made.
 - The second switch port is dedicated to connect the remote control or BMS.
 - The ethernet ports 3-8 are for the connection to each heat pump in order from units 1 to 6.

5. Configure the Network Settings of The Sequencer as follows:

- I. Press PRG or  button on the remote interface and enter user password, 0077.



- II. Go to **E. User Settings** and press enter.

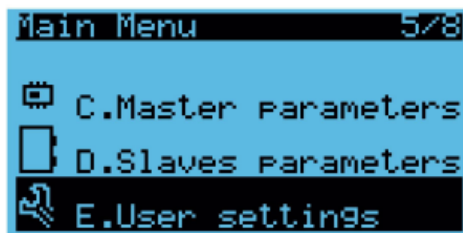

- III. Go to d. Network Configuration tab and press enter.

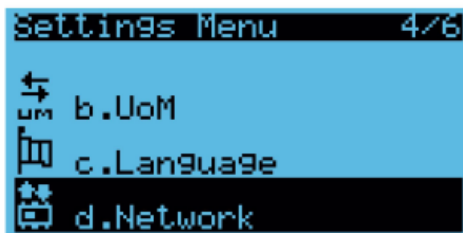

- IV. Input the following settings:

- Enable: Static
- Set IP address to 192.168.1.152
- MASK: 255.255.255.000
- GW: 192.168.1.1
- DNS: 192.168.1.1

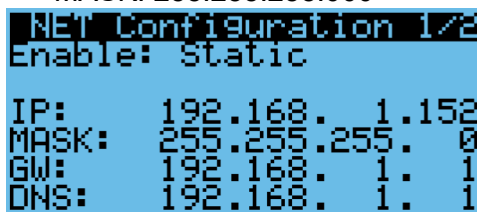

6. Search and record the IP address of each heat pump being connected to the sequencer. Set Client parameters to match IP address of each unit in order. To set these parameters for each unit:

- I. Press program button PRG or the  button on the remote interface of the Sequencer.
- II. Enter Service password 0077.



- III. Scroll down to Clients parameters.

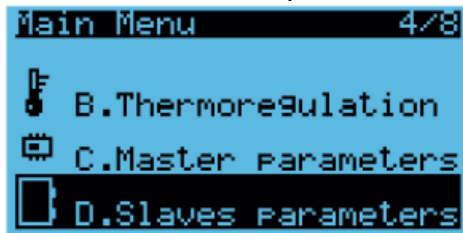

- IV. Change IP address of unit inside Sequencer to match IP address on each heat pump.

- V. Ensure the Client ID # is matches the number of the unit (example: Unit 3 has Client ID 3).

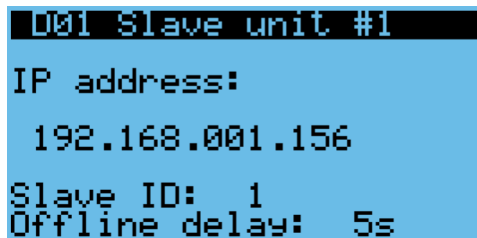

- VI. Repeat these steps until all units have their matching IP addresses in the Client Parameters.

7. Disable Temperature Probes BT1 and BT2 for each unit. These settings are accessed through the remote interface of each unit.
- I. Using a browser, enter the IP address of a unit into the address bar. For more information on the remote interface, reference L-OMM-013.
 - II. Select User Setting.
 - III. Set temperature probes BT1 and BT2 to DISABLED.

If individual unit heat exchanger modules and primary pumps are being used, these pumps must be ENABLED in the Service menu.

If a single external heat exchanger and primary pump is being used, the individual unit primary pumps must be DISABLED in the Service menu.

Please note: This is not a recommended application, as the Lync heat exchanger modules are only designed to work with a single heat pump. Note that this is not a recommended application.

8. Ensure that there are no errors or alarms displayed. Hold the alarm button down for three seconds to reset all alarms. Press the alarm button to check for the status of the alarms. If none are present the alarm screen will appear as follows:



4. USER INTERFACE

4.1. Electrical Panel User Terminal

The user interface is an electrical panel with a semi-graphic terminal.



The terminal has six physical buttons, which function as follows:

- Alarm	Display the list of active alarms Manually reset alarms
- Prg	Access the main menu
- Esc	Return to the previous screen
Up - Down	Navigate between the display screens or increase/decrease the value
- Enter	Switch from parameter display to edit Confirm value and return to the parameter list

4.2. Main Screen and Control Logic

The main screen, which is the default display, shows the following information for the unit:

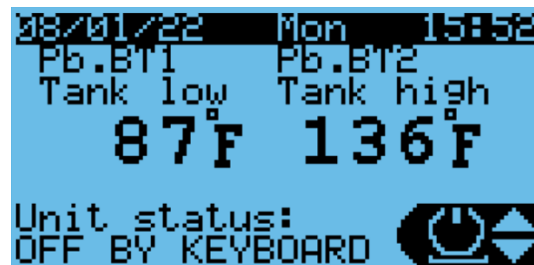

- BT1 probe value (tank low/cool side probe)
- BT2 probe value (tank high/hot side probe)
- ON/OFF alarm status
- System date and time

4.2.1. Anti-Legionella Management

The Aegis Sequencer includes a control algorithm called “anti-Legionella function.” This function does not apply to the North American market and should not be used because the required heat exchanger module is not compatible with this feature. This information is included for reference only. The anti-Legionella function can be activated either on a set schedule or manually via the interface or BAS.

⚠ WARNING!

It is recommended that this function, if used, be scheduled for periods of low demand to reduce the risk of scalding. A master mixing valve and/or point-of-use mixing valve is required to prevent scalding. Lync recommends the DigiTemp line of digital mixing valves.

NOTE: The anti-Legionella function may be used to mitigate the risk of waterborne Legionella in the tank array and near-tank piping. This function will not automatically disinfect building system piping. A proper waterborne pathogen mitigation strategy should be used. *See ASHRAE Standard 188.*

The BTL probe placed at the inlet of the heat exchanger is required to manage the anti-Legionella function. The anti-Legionella cycle consists of two phases:

1. Phase 1

- The "Anti-Legionella active" relay contact is closed.
- All the units are forced to a set point value of 194°F [90° C] (settable value).
- With BT1 up to Phase 1 Set BTL (e.g. 140°F [60° C] settable value), all heat pumps are activated.
- With BT1 over Phase 1 Set BTL, the system keeps only one unit active until the temperature of the BTL probe reaches a predefined Phase 1 Set BTL set point, preset at 131°F [55° C].

The set point must be lower than the parameter "Maximum inlet water temperature" set on the Aegis unit. This function is only available on units with High Inlet Temperature function.

2. Phase 2

- When the Phase 1 Set BTL set point is reached, the units will switch off (compressor OFF), while the secondary pump is brought to a fixed speed. Once the BTL probe reaches the Phase 2 Set BTL (e.g. 158°F [70°C], the secondary pump also switches off.
- The anti-Legionella cycle is finished once this condition lasts for a settable time frame (default 60 seconds).
- The maximum allowable duration of the anti-Legionella cycle is set to a default of [2 min], after which the unit exits the cycle and returns to normal operation. This generates a warning that the anti-Legionella cycle was not completed correctly.
- The unit defrost function has priority over the Aegis Sequencer anti-Legionella management.

Sections 4.2.2. and 4.3.3. contain more information on anti-Legionella.

4.2.2. Secondary Pump Management

The secondary pump management allows coordinated operation between the primary pumps installed inside the units or on the primary loop and those on the domestic (secondary) side between the intermediate exchanger and the storage tanks. The coordinated operation of pumps is necessary to ensure the correct delivery temperature of the water to the tank system. The secondary pump could have a different flow than what's installed on the unit, and must be managed independently by an additional temperature probe, positioned downstream of the intermediate exchanger (*see 5.2.3 for information on the settings*).

Aegis heat pump water heaters are supplied with an engineered heat exchanger module, sized for an individual heat pump. While the Aegis sequencer can support a single, shared heat exchanger and pump, Lync strongly recommends using individual heat exchangers and pumps for multiple unit applications.

Please note that the speed regulation of the domestic side pump is independent from the speed regulation of the primary pump.



The function is based on the following:

- proportional-integral-derivative control, which has as an input value
- the temperature value read by the BT3 probe
- its position at the exchanger outlet
- two temperature setpoints:
 - Unit delivery setpoint
 - Anti-Legionella setpoint (if the function is active)

An additional fixed speed set point is needed for the anti-Legionella Phase 2.

See 5.2.2 for more information on Thermoregulation.

4.3. User Settings

On the main screen, the UP  and DOWN  buttons can be used to scroll through the user menu of basic functions. Use the ENTER  button to select options. No password is needed to access and edit these functions.



4.3.1. On/Off



The system can be turned on and off from the user menu. The status is displayed on the main screen, and can be changed using the UP and DOWN keys. The OFF option on the screen has priority over the ON/OFF commands from digital input or BMS.



4.3.2. Set



Through the set point menu, it is possible to:

1. Define the set points for probes BT1 and BT2 and the corresponding differential bands.

```
Setpoint
Set BT1:      86.0°F
Diff.band:    9.0°F

Set BT2:      140.0°F
Diff.band:    9.0°F
```

2. Define the set points related to probes S2-S6. By default, the set point is automatically calculated. To use a custom set point, manually change the option "Enable auto set" to "NO" and change the value in the "Manual set" field.

```
Setpoint step 2
Actual set:   113.0°F
Step probe:   89.3°F
Manual set:   95.0°F
Diff.band:   5.4°F

Enable auto set: YES
```

4.3.3. Anti-Legionella



Through the anti-Legionella menu, it is possible to do the following:

1. Enable the anti-Legionella function and define the recurring starting time (day, hour, and minute). The maximum time for a forced exit can also be defined.

```
Antileg.scheduler
Enable:        NO
Start day:     SUN
Start time:    22:00
Max time:     120min
```

2. Define the BT1 and BTL set points, and the fixed speed pump set.

```
Antileg.scheduler
Phase 1
Set BT1:      140.0°F
Set BTL:      131.0°F
Phase 2
Set BTL:      158.0°F
Pump set:     30.0%
```

- View anti-Legionella status (phase 1 running or completed, phase 2 elapsed time).

```
Antileg.scheduler
Phase 1: ---
Phase 2:
  Min.time:    60s
  Elapsed:    --s
```

- Manually start and stop the function.

```
Antileg.scheduler
Manual start:NO
Manual stop: NO
```

4.3.4. Info



Through the info menu, you can view the following:

- The general status of the system (tank temperature probes and plant power request).

```
Manager Input/Output
AI01 Probe BT1  90.8f
AI02 Probe BT2 139.0f
AI03 Sec.side  113.1f
AI04 Antileg.   89.5f
AI05 Step 2    116.9f
Plant request: 100.0%
```

- Status of the secondary side (set point, supply water temperature, current speed).

```
Secondary PUMP
Curr.set:    105.0f
Sec.side:    142.9f
Curr.speed:  100.0%
```

- The basic information of the individual units (unit inlet water temperature and gas-cooler outlet, pump speed, power required by the Sequencer).

```
Plant info
UNIT 1      UNIT 2
Out:  158.0f▶ 158.5f▶
Pwr:   100%   100%
PMP:   100%   100%
In:    83.8f◀ 100.9f◀
Plant request: 100.0%
```

- Plant request: Plant (system) power request
- In: Unit inlet water temperature

- Out: Unit outlet water temperature
- Pwr: Power requested to the unit
- Pmp: Pump

4. Software and firmware information.



4.3.5. Unit Info Menu



Through these menus, it is possible to display detailed information on the units connected to Aegis Sequencer:



1. Unit operating mode and status of remote OFF digital contact (with open contact the unit is forced OFF and is no longer available for the Sequencer regulation).

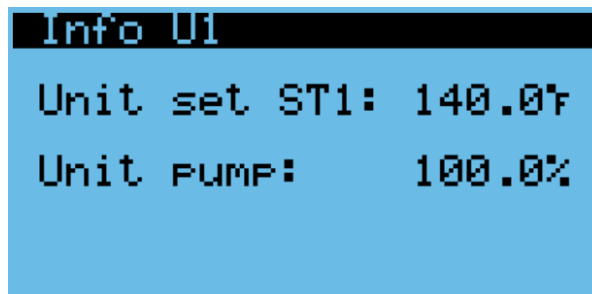

2. Unit set ST1: Supply water temperature set point used by the unit
3. Unit pump: Current unit pump speed

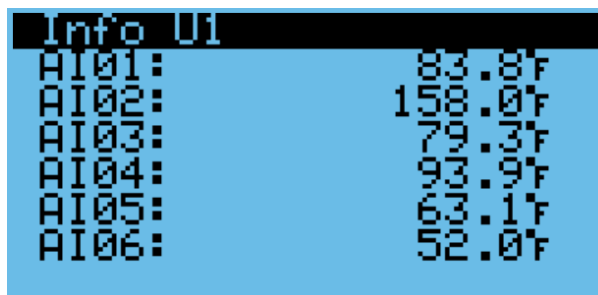

4. AI01 – AI12: Unit temperature and pressure probe values

5. MAIN MENU

Regardless of the displayed screen, pressing the programming key accesses the password entry screen, which allows access to the main menu shown below.

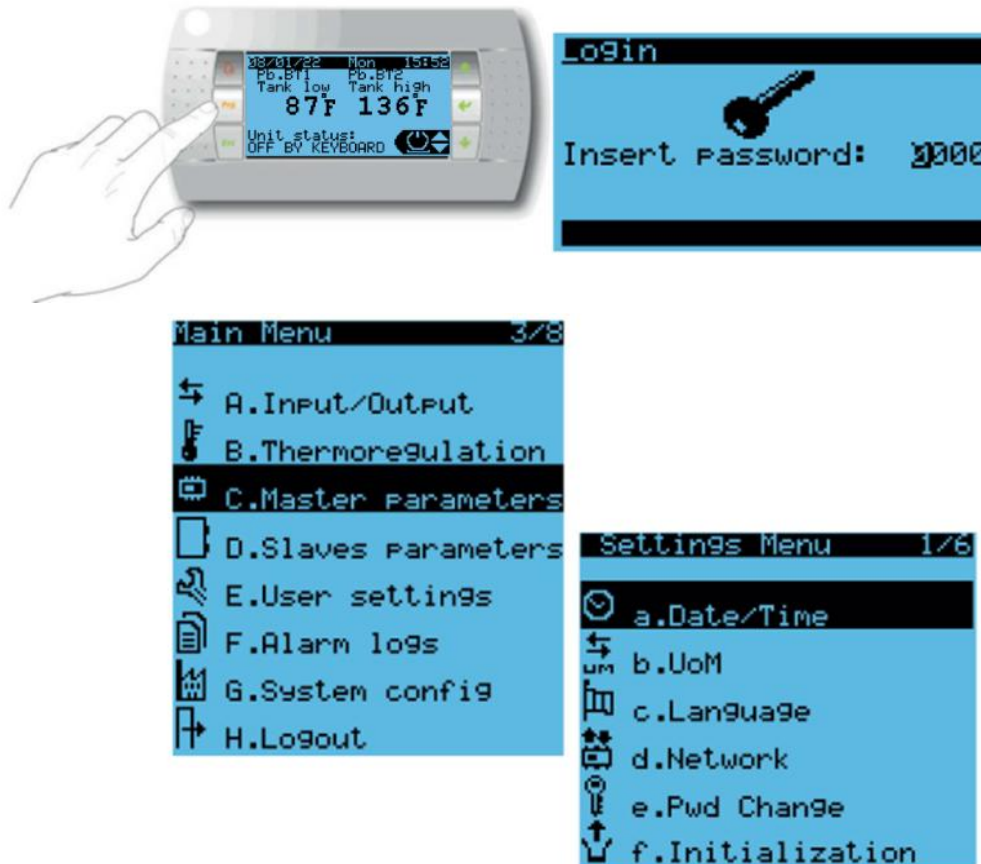

The program has three different password levels with different permissions:

- **USER:** Can change the basic settings (e.g. date/time), Default password: 0001
- **SERVICE:** (technical/maintenance assistance) Lets the technician modify some operating parameters. This setting is reserved for technical assistance centers and authorized personnel. The default password is 0077.
- **MANUFACTURER:** Allows viewing and editing access to all parameters. The default password is 0528.

In each screen, the access needed to edit the parameters is shown in the upper left corner, always with the same codes. An example follows (M: Manufacturer, S: Service):

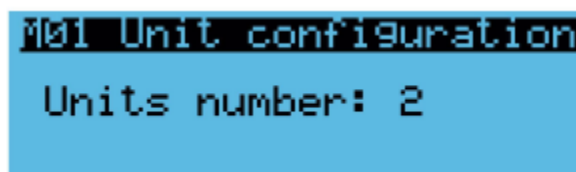

Once the password is entered, the system will be unlocked for five minutes from the last time a key was pressed, after which the password will need to be re-entered to access the parameters of the advanced functions. To log out without waiting 5 minutes, use the menu G. Log-Out.

5.1. Menu Loops and Layout

In each menu, the screens are organized into loops: the UP and DOWN buttons scroll all the screens in the same menu. The screens are organized so that the down button (scrolling downwards) accesses the most frequently used screens, while those that are used least (e.g. configuration) are accessed by pressing the up button (scrolling upwards).

The individual menus use a code that helps identify the menu:

- 1st character (uppercase): main menu code
- 2nd character (lowercase): submenu, if any
- 3rd character (number): index inside the loop

Example: clock setting, menu code Da1 includes Menu D. User Settings, sub-menu a. Date/Time, and first menu screen of the loop “1”

```

Da1 Date/Time change
Format:          DD/MM/YY
Date:           13/02/19
Hour:           14:29:39
Day:            Wednesday
  
```

5.1.1. Menu A: Input/Output

```

Main Menu      1/8
← A.Input/Output
⚙ B.Thermoregulation
🔌 C.Master parameters
  
```

In the A. Input/Output menu it is possible to change the actions of digital inputs and outputs to normally open or normally closed.

```

A01 Master dig.input
ON/OFF by DI:
DISABLED
System ON if:
---
```

Menu A01: Turning the system on/off by digital input and choice of NO/NC.

```

A02 Master dig.input
Alarm by DI:
ENABLED
Alarm if:
OPEN
```

Menu A02: Enabling the system alarm with a forced stop via external digital input and choice of NO/NC.

5.1.2. Menu B: Thermoregulation

```
Main Menu 2/8
↔ A.Input/Output
⌂ B.Thermoregulation
⚙ C.Master parameters
```

The B. Thermoregulation menu can be used to modify the operating set point of the individual units.

```
B01 Units set point
Actual set: 140.0°F
Heating set: 140.0°F
Antileg. set: 194.0°F
En. power limit: YES
```

Menu B01: Set points are transmitted to the client units in normal operating mode, and during the anti-Legionella cycle. The actual set point in use is also displayed.

5.1.3. Menu C: Manager Parameters

```
Main Menu 3/8
↔ A.Input/Output
⌂ B.Thermoregulation
⚙ C.Master parameters
```

Through the C. Manager parameters menu, it is possible to modify the operating parameters of the secondary pump to adapt it to the individual installations.

```
C01 Secondary PUMP
Enable: YES
Set offset: 35.0°F
Reg.band: 9.0°F
PID Td: 0.0s
PID Ti: 0.0s
Curr.speed: 0.0%
```

Menu C01: Enabling of the secondary pump function and pump offset/PID parameters.

```
C02 Secondary PUMP
Manual mode: NO
Manual speed: 0.0%
Low limit: 30.0%
High limit: 100.0%
```

Menu C02: Enabling of pump manual operation and defining pump min/max limits. This mode allows you manually set the pump speed within the low and high limits.

5.1.4. Menu D: Clients Parameters

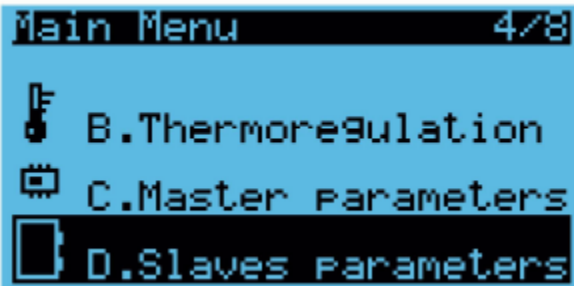

Through the D. Clients parameters menu, it is possible to define the client Aegis devices IP addresses.

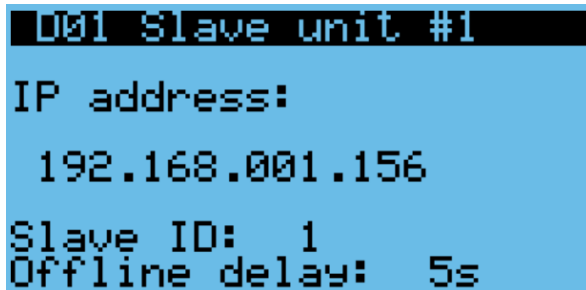

Menu D01: Client device IP address. The Client ID and offline delay parameters can be left on the factory defaults.

5.1.5. Menu E: User Settings

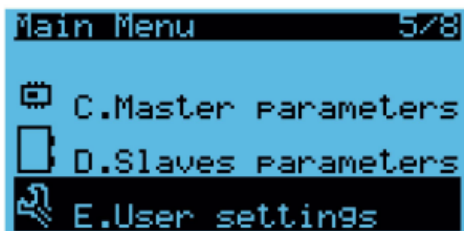

The E. User settings menu is made up of several submenus, through which you access the following screens:

- a. Date/Time: Date and Time Settings – Menu Ea1

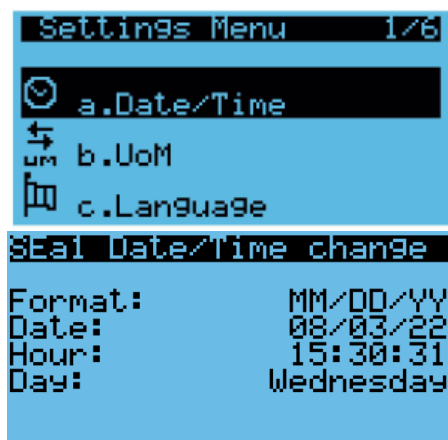

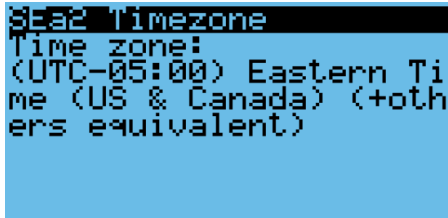

- b. UoM: Unit of Measure – Menu Eb1

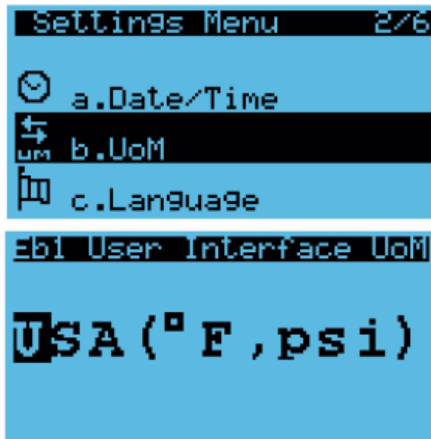

Menu Eb1: Unit of Measure shown on the display

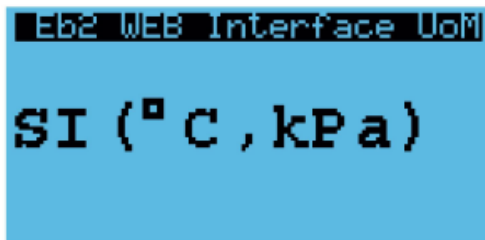

Menu Eb2: Unit of measure used on the web interface

- c. Language: System Language Settings – Ec1

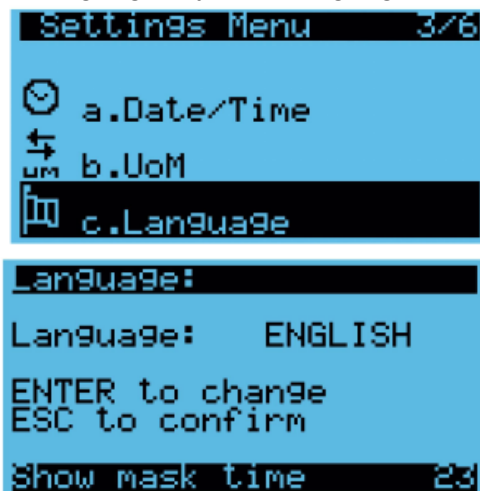

"Show mask time" is the idle count down. When the timer runs out the display goes back to the main screen. When a button is pressed the 30 second timer starts over.

- d. Network: Serial and Ethernet Port Configurations and On/Off options – Ed1

Note that any changes to the network settings will require a reboot of the sequencer

```
Settings Menu 4/6
↑
↓
b.UoM
c.Language
d.Network
```

```
Ed1 Remote on/off

On/Off by BMS: NO
```

```
Ed2 Ethernet protocols
Modbus client
Polling: 1000ms
Modbus server
Port: 502
BACnet
Obj.instance: 200
Port: 47808
```

Menu Ed2: Modbus and BACnet Protocol Parameters

```
Ed3 NET Configuration

Press "Enter" for
Network Configuration
```

Menu Ed3: Ethernet Port Settings mask access – press ENTER

```
NET Configuration 1/2
Enable: Static

IP: 192.168. 1.152
MASK: 255.255.255. 0
GW: 192.168. 1. 1
DNS: 192.168. 1. 1
```

Menu Ed4: Ethernet Port IP Settings

```
NET Configuration 2/2

Update Config? No
```

Menu Ed5: Ethernet Port Settings Confirmation – Select Yes to update the Configuration

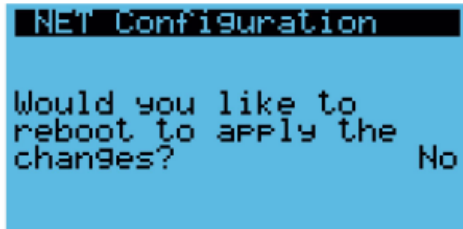

Menu Ed6: System reboot is needed to confirm the changes – select Yes

- e. Pwd Change: Password Change

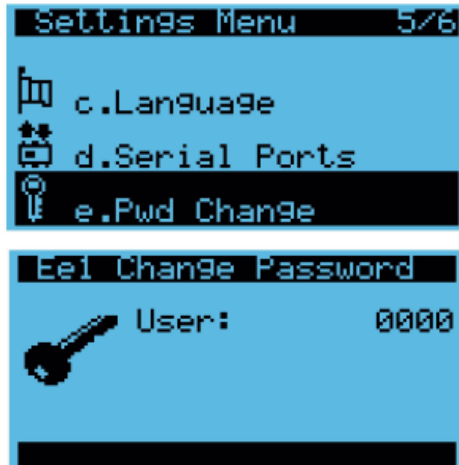

Menu Ee1: Password Change. The possibility of modification depends on the password level used to access the menu. It is possible to change the password of the current level as well as the lower levels. Lync strongly recommends against changing the default passwords, as lost passwords are not able to be recovered.

- f. Initialization: System Initialization



Menu Ef1: Alarm initialization. Allows a technician to delete the alarm log, and reset automatic alarm counters with a limit on the number of events over a certain period. Access to the mask is reserved for the Service and Manufacture password levels.

- Menu F: Alarm Logs. This menu allows you to view and scroll through the alarm history. See *Section 6 for more information.*

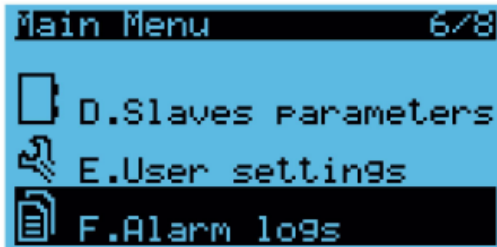

- Menu G: System Config. Through the System config menu, you can access the system configuration (number and type of installed units, network addresses, functions present, etc.). Access to this menu is reserved for manufacturer password level.

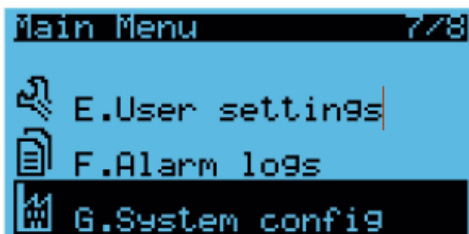

- Menu H: Logout. The Logout menu allows you to exit from the main menu.



Logout Menu: Press the Enter key to return to the main menu and reset the password hold time.

6. ALARM MANAGEMENT

6.1. Alarm Screens and LED

Pressing the ALARM key  can result in two different scenarios, depending on whether an alarm is active. If there is no active alarm, the following screen is displayed:



This screen makes it possible to easily go to the alarms log using the ENTER key (see section 6.2.).

If there is at least one alarm, the alarms screen is sorted by alarm code from lesser to greater impact to the system. For instance, If one of the temperature probes is disconnected the sequencer turns off all units and so is listed first. An alarm to a single unit is listed afterwards as the sequencer can still have other units operating.

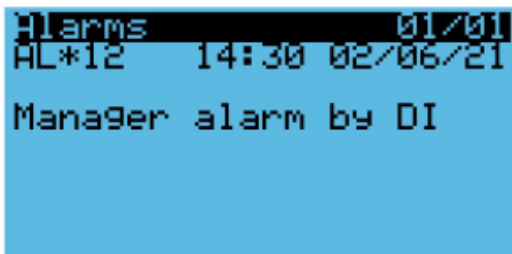

In every alarm screen, the alarms log can be displayed by pressing ENTER. The red LED under the ALARM button will display as follows:

- **Off:** no active alarm
- **Flashing:** at least one active alarm, display shows a screen that is not part of the alarms loop.
- **On:** at least one active alarm, and a screen that is part of the alarms loop is displayed.

From the last menu of the loop it is possible to reset the active alarms by pressing and holding the alarm key for 3 seconds.



6.2. Alarms Log

The Alarms Log menu allows access to the following alarms log display screen.

A screenshot of a terminal-style display screen with a blue background and white text. The text is as follows:

```
data logger Record:01  
02 H210 00:49 24/09/18  
  
Unit #2 offline  
  
Event:      Start
```

The alarms log memorizes the unit operation status when the alarms are triggered. Each log entry is an event that can be displayed from among all the events available in the memory.

The information saved in the alarms screen will also be saved in the alarms log. The maximum number of events that can be saved is 64. Once the limit is reached, the most recent alarm will overwrite the oldest one.

The alarms log can be cleared in the Settings menu (mask Ef1) through the specific command, or by pressing and holding the alarm key for 3 seconds.

7. REMOTE INTERFACE

The ethernet connection for the remote interface of the Sequencer connects into the second port of the ethernet switch inside of the Sequencer. The other end of the ethernet cable will then connect to a computer.

To see the remote interface of the Sequencer, the IP address of the Sequencer must be entered in an internet browser followed by “/commissioning/index.html”. The default IP address can be set to 192.168.1.160 or 192.168.1.151, depending on the unit serial number.

Example: 192.168.1.160/commissioning/index.html

From this remote interface the Sequencer can be controlled in the pGD1 tab. Information about the Sequencer and the system can also be accessed through this remote interface in the other tabs on the left side of the screen.

By searching the IP address of each unit in a new tab on an internet browser, the unique remote interface of each unit can be accessed via the same ethernet connection. This interface gives access to change the user and service setting of the individual Aegis units as well as the diagram showing the components of the heat pump operating.

APPENDIX A – PLANT DRAWINGS AND SENSOR LOCATIONS

The following pages show examples of some typical systems with the most common combinations of unit and storage tank quantities.

The examples are subject to change based on the customer's needs.

A.1. Plants with Two Units

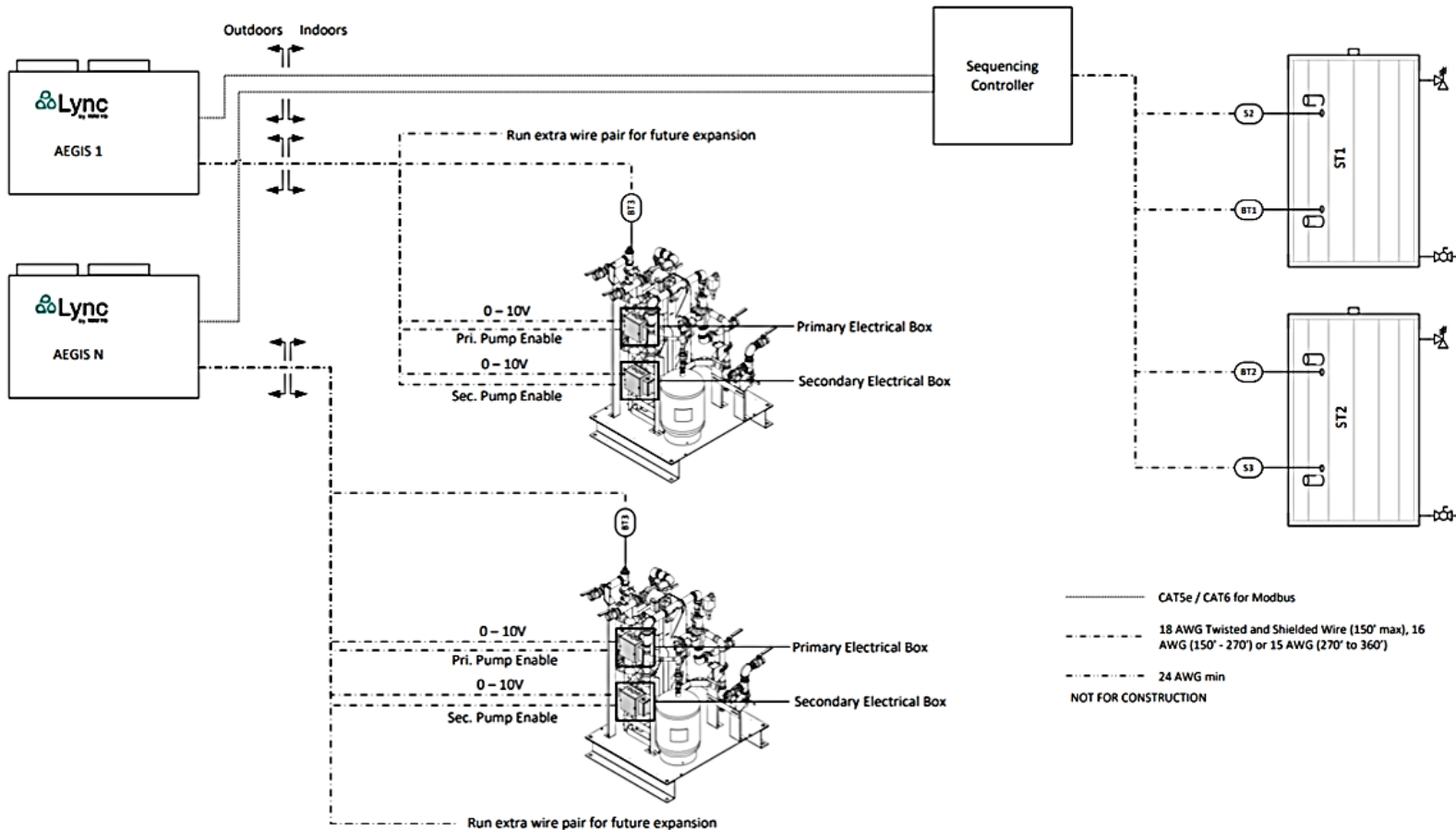

Notes:

1. Each Aegis unit is wired as shown to the pump skids. It is not possible to run multiple Aegis units to a single pump skid.
2. The sequencing controller requires the number of sensors to be equal to the number of heat pumps, plus one. Thus, if three Aegis units are used, BT1, S2, S3, and BT2 are required. Install other sensors as a reference if desired.

A.2. Plants with Three Units

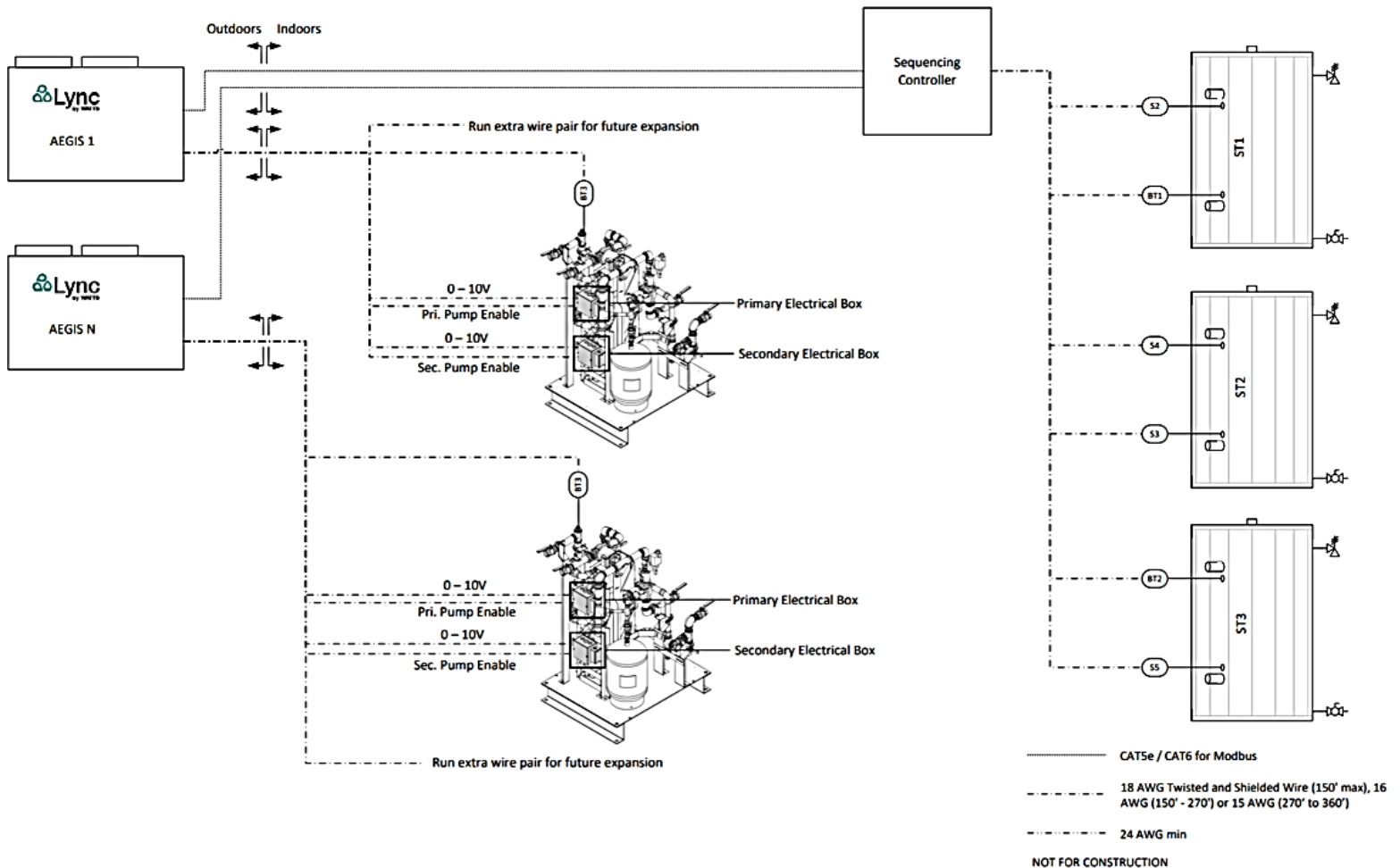

Notes:

1. Each Aegis unit is wired as shown to the pump skids. It is not possible to run multiple Aegis units to a single pump skid.
2. The sequencing controller requires the number of sensors to be equal to the number of heat pumps, plus one. Thus, if three Aegis units are used, BT1, S2, S3, and BT2 are required. Install other sensors as a reference if desired.

A.3. Plants with Four Units

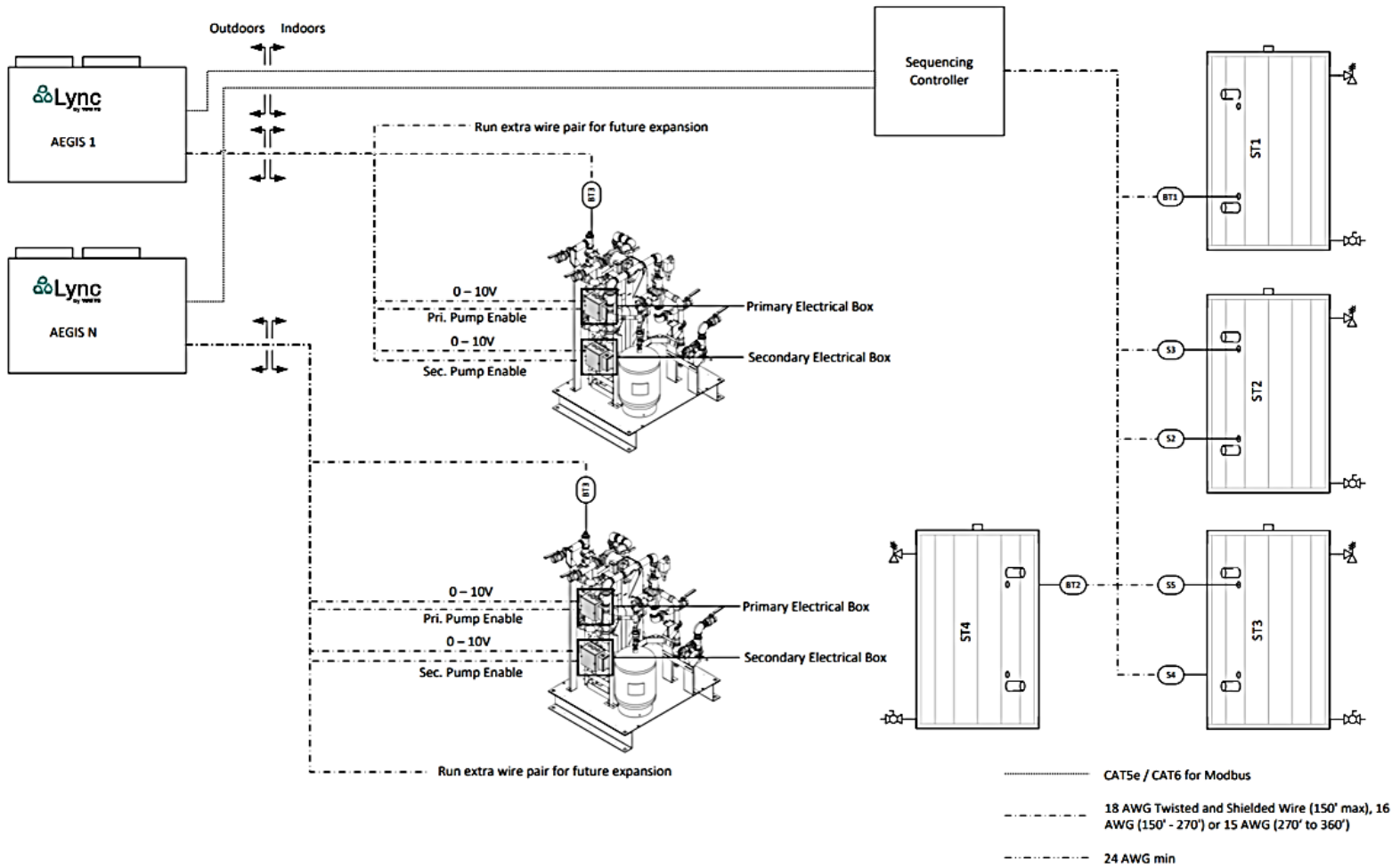

Notes:

1. Each Aegis unit is wired as shown to the pump skids. It is not possible to run multiple Aegis units to a single pump skid.
2. The sequencing controller requires the number of sensors to be equal to the number of heat pumps, plus one. Thus, if three Aegis units are used, BT1, S2, S3, and BT2 are required. Install other sensors as a reference if desired.

A.4. Plants with Five Units

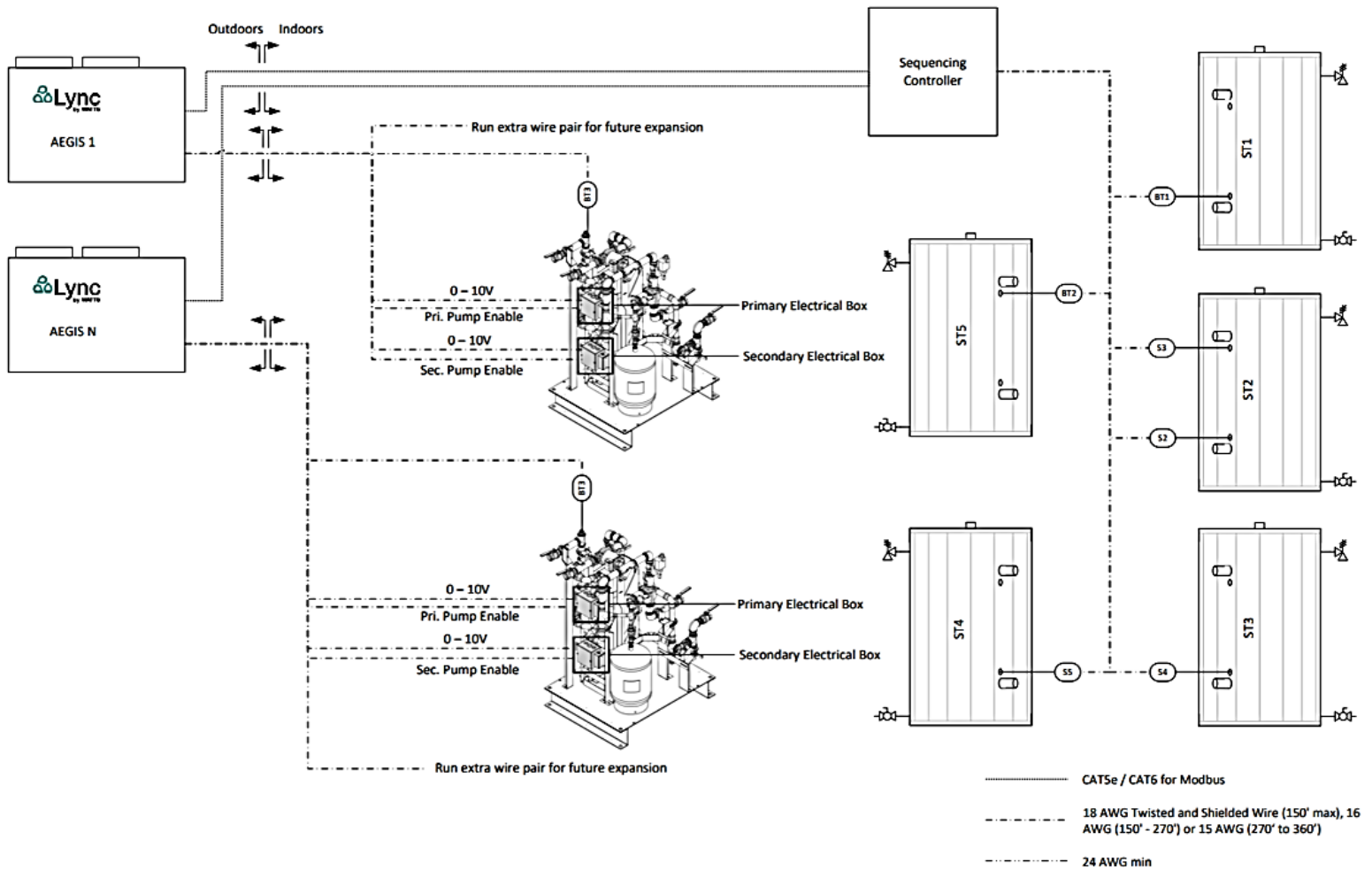

Notes:

1. Each Aegis unit is wired as shown to the pump skids. It is not possible to run multiple Aegis units to a single pump skid.
2. The sequencing controller requires the number of sensors to be equal to the number of heat pumps, plus one. Thus, if three Aegis units are used, BT1, S2, S3, and BT2 are required. Install other sensors as a reference if desired.

APPENDIX B - WIRING CONNECTIONS

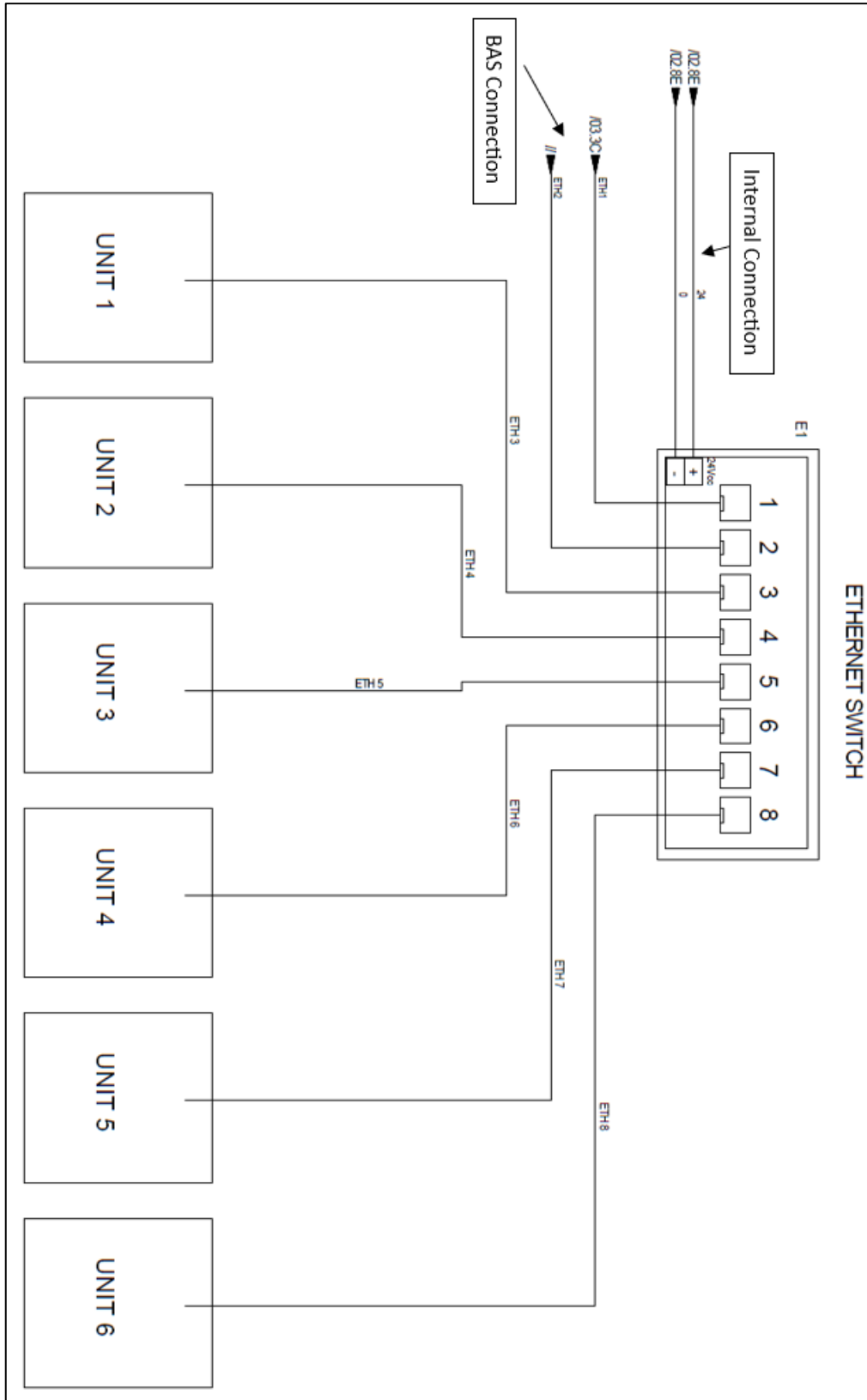

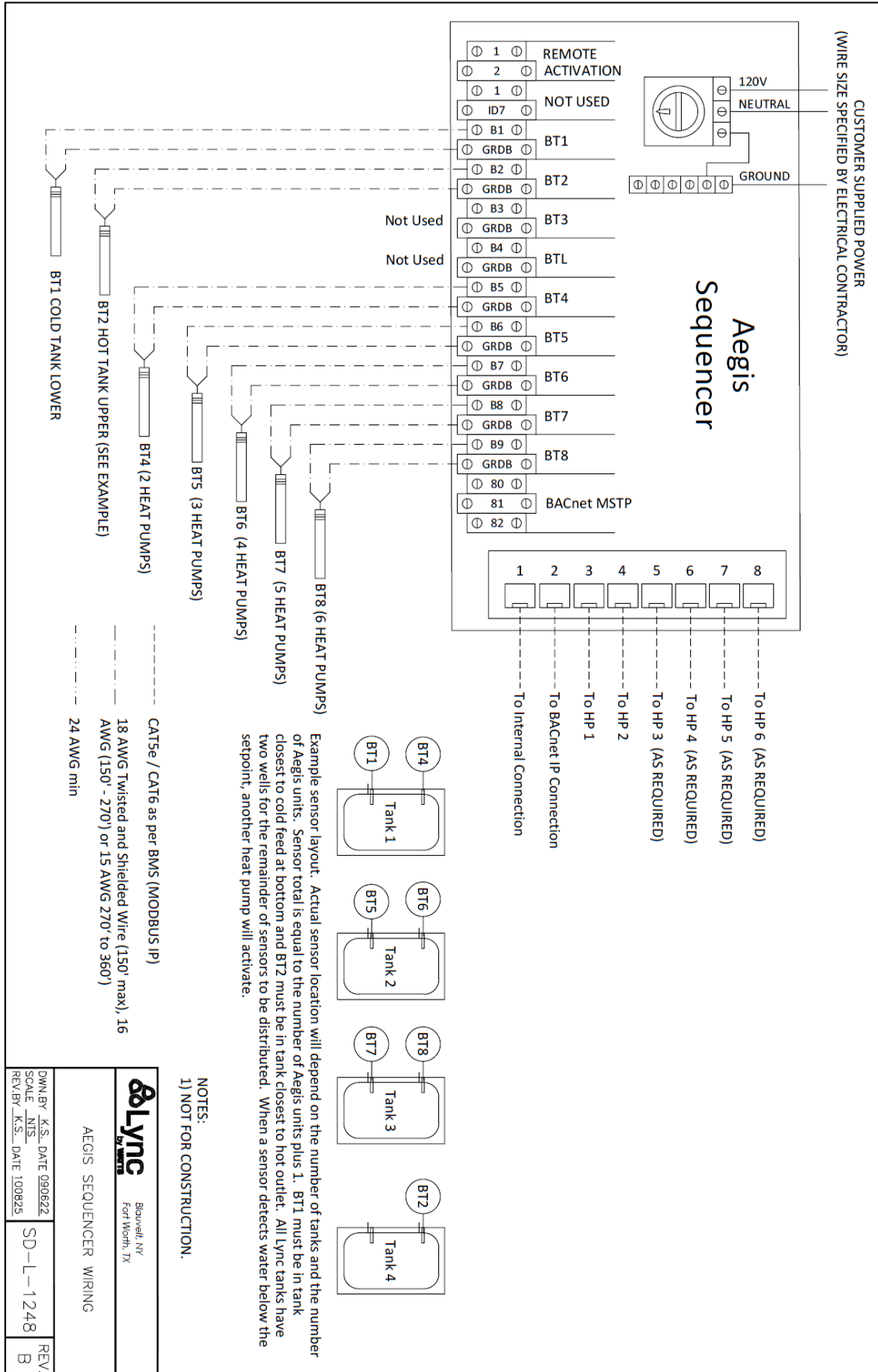

APPENDIX C - PART NUMBERS

Description	Qty	Lync Part Number
User Interface	1	164677
Control board	1	164678
Temperature sensor	9	159424
Ethernet switch	1	164679
30A 600V 2x38mm fuse	1	164680
4A 600V 10.3x38mm fuse	2	164681
4A 500 V fuse	1	164682
220VAC-24VDC 30W transformer	1	164683
Mini relay 2 contacts 24VDC 8A	5	158720
Relay socket 2 contacts series 95	5	158706
Main switch 20A	1	164684
Padlockable red power knob	1	164685
Door lock plate	1	164686
Door mounting plate	1	164687
Power switch extension 300mm	1	164688

APPENDIX D – BAS COMMUNICATION POINTS

The Aegis Sequencer can be connected to external BMS (BAS) in two different protocols:

- 1) BACnet
- 2) Modbus

In the case of Modbus, both RTU or TCP/IP communication is available.

- a) RTU: connection using two wires directly to serial port in the Sequencer.
- b) TCP/IP: connection using port number 2 in the network switch.

In the case of BACnet, connection is made to port number 2 in the network switch. Not every individual unit communication point will be available through the Sequencer. Available points are shown in the table below.

Version 1.3 BACnet Server Configuration Settings		
Device Instance	Timeout	Command Timeout
General Mng. Object Instance BACnet	3000	1500

	Object Name	Object Instance	Description
OBJECT_DEVICE:200	uPC3200	200	CAREL Multitasking Controller
OBJECT_ANALOG_VALUE:1	ManagerHP90_BT1.Val	1	Tank BT1 probe (lowest system temperature) - Value
OBJECT_ANALOG_VALUE:2	ManagerHP90_BT2.Val	2	Tank BT2 probe (highest system temperature) - Value
OBJECT_ANALOG_VALUE:3	ManagerHP90_SecondaryPumpProbe.Val	3	Secondary side pump probe - Value
OBJECT_ANALOG_VALUE:4	ManagerHP90_AntilegionellaProbe.Val	4	Antilegionella probe - Value
OBJECT_ANALOG_VALUE:5	ManagerHP90_ProbeStep_2.Val	5	Tank step 2 probe - Value
OBJECT_ANALOG_VALUE:6	ManagerHP90_ProbeStep_3.Val	6	Tank step 3 probe - Value
OBJECT_ANALOG_VALUE:7	ManagerHP90_ProbeStep_4.Val	7	Tank step 4 probe - Value
OBJECT_ANALOG_VALUE:8	ManagerHP90_ProbeStep_5.Val	8	Tank step 5 probe - Value
OBJECT_ANALOG_VALUE:9	ManagerHP90_ProbeStep_6.Val	9	Tank step 6 probe - Value
OBJECT_ANALOG_VALUE:10	SecondaryPumpSpeed.Val	10	Secondary side pump speed - Value
OBJECT_ANALOG_VALUE:11	ManagerHP90_SetBT1	11	Set point BT1
OBJECT_ANALOG_VALUE:12	ManagerHP90_SetBT1_Differential	12	Differential band SetBT1
OBJECT_ANALOG_VALUE:13	ManagerHP90_SetBT2	13	Set point BT2
OBJECT_ANALOG_VALUE:14	ManagerHP90_SetBT2_Differential	14	Differential band SetBT2
OBJECT_ANALOG_VALUE:15	ManagerHP90_SetSupplyUnits	15	Units hot water set point (ST01)
OBJECT_ANALOG_VALUE:16	ManagerHP90_SetAntilegionellaUnits	16	Units antilegionella set point
OBJECT_ANALOG_VALUE:17	StepsManualSetValue[2]	17	Set point Step 2
OBJECT_ANALOG_VALUE:18	StepsDifferentialBand[2]	18	Differential band Step 2
OBJECT_ANALOG_VALUE:19	StepsManualSetValue[3]	19	Set point Step 3
OBJECT_ANALOG_VALUE:20	StepsDifferentialBand[3]	20	Differential band Step 3
OBJECT_ANALOG_VALUE:21	StepsManualSetValue[4]	21	Set point Step 4
OBJECT_ANALOG_VALUE:22	StepsDifferentialBand[4]	22	Differential band Step 4
OBJECT_ANALOG_VALUE:23	StepsManualSetValue[5]	23	Set point Step 5
OBJECT_ANALOG_VALUE:24	StepsDifferentialBand[5]	24	Differential band Step 5
OBJECT_ANALOG_VALUE:25	StepsManualSetValue[6]	25	Set point Step 6
OBJECT_ANALOG_VALUE:26	StepsDifferentialBand[6]	26	Differential band Step 6

OBJECT_ANALOG_VALUE:27	DevicesRotation_Mng.PwrReqLimit	27	Power request limitation
OBJECT_ANALOG_VALUE:101	Units_AI01[1]	101	Unit 1 - Hot water IN temperature
OBJECT_ANALOG_VALUE:102	Units_AI02[1]	102	Unit 1 - Hot water OUT temperature
OBJECT_ANALOG_VALUE:201	Units_AI01[2]	201	Unit 2 - Hot water IN temperature
OBJECT_ANALOG_VALUE:202	Units_AI02[2]	202	Unit 2 - Hot water OUT temperature
OBJECT_ANALOG_VALUE:301	Units_AI01[3]	301	Unit 3 - Hot water IN temperature
OBJECT_ANALOG_VALUE:302	Units_AI02[3]	302	Unit 3 - Hot water OUT temperature
OBJECT_ANALOG_VALUE:401	Units_AI01[4]	401	Unit 4 - Hot water IN temperature
OBJECT_ANALOG_VALUE:402	Units_AI02[4]	402	Unit 4 - Hot water OUT temperature
OBJECT_ANALOG_VALUE:501	Units_AI01[5]	501	Unit 5 - Hot water IN temperature
OBJECT_ANALOG_VALUE:502	Units_AI02[5]	502	Unit 5 - Hot water OUT temperature
OBJECT_ANALOG_VALUE:601	Units_AI01[6]	601	Unit 6 - Hot water IN temperature
OBJECT_ANALOG_VALUE:602	Units_AI02[6]	602	Unit 6 - Hot water OUT temperature
OBJECT_BINARY_VALUE:1	UnitOn	1	Unit On status: TRUE = Unit ON
OBJECT_BINARY_VALUE:2	GlbAlrm	2	Global alarms (at least one active alarm)
OBJECT_BINARY_VALUE:3	AntilegionellaFunction.Active	3	Antilegionella function status
OBJECT_BINARY_VALUE:4	SecondaryPumpFunction.WaterPumpDigitalOutput	4	Secondary side pump status
OBJECT_BINARY_VALUE:5	AntilegionellaFunction.Phase2Running	5	Antilegionella function status phase 2
OBJECT_BINARY_VALUE:6	ID1.Val	6	ON/OFF dig. input status - Value
OBJECT_BINARY_VALUE:7	ID2.Val	7	External alarm dig. input status - Value
OBJECT_BINARY_VALUE:8	OnOffUnitMng.BmsOnOff	8	Unit On/Off by BMS
OBJECT_BINARY_VALUE:9	AlarmMng.AlrmResByBms	9	Alarm reset by BMS
OBJECT_BINARY_VALUE:10	AntilegionellaFunction.StartManual	10	Antilegionella function manual start
OBJECT_BINARY_VALUE:11	AntilegionellaFunction.StopManual	11	Antilegionella function manual stop
OBJECT_BINARY_VALUE:12	AL_Manager_Probe_BT1.Active	12	Alarm status BT1 probe
OBJECT_BINARY_VALUE:13	AL_Manager_Probe_BT2.Active	13	Alarm status BT2 probe
OBJECT_BINARY_VALUE:14	AL_Manager_Probe_SecPump.Active	14	Alarm status secondary pump probe
OBJECT_BINARY_VALUE:15	AL_Manager_Probe_Antilegionella.Active	15	Alarm status antilegionella probe
OBJECT_BINARY_VALUE:16	AL_Manager_Probe_Step2.Active	16	Alarm status step 2 probe
OBJECT_BINARY_VALUE:17	AL_Manager_Probe_Step3.Active	17	Alarm status step 3 probe
OBJECT_BINARY_VALUE:18	AL_Manager_Probe_Step4.Active	18	Alarm status step 4 probe
OBJECT_BINARY_VALUE:19	AL_Manager_Probe_Step5.Active	19	Alarm status step 5 probe

OBJECT_BINARY_VALUE:20	AL_Manager_Probe_Step6.Active	20	Alarm status step 6 probe
OBJECT_BINARY_VALUE:21	AL_Manager_DI.Active	21	Alarm status DI Manager
OBJECT_BINARY_VALUE:22	AL_Offline_U1.Active	22	U1 offline - Alarm status
OBJECT_BINARY_VALUE:23	AL_Offline_U2.Active	23	U2 offline - Alarm status
OBJECT_BINARY_VALUE:24	AL_Offline_U3.Active	24	U3 offline - Alarm status
OBJECT_BINARY_VALUE:25	AL_Offline_U4.Active	25	U4 offline -Alarm status
OBJECT_BINARY_VALUE:26	AL_Offline_U5.Active	26	U5 offline -Alarm status
OBJECT_BINARY_VALUE:27	AL_Offline_U6.Active	27	U6 offline -Alarm status
OBJECT_BINARY_VALUE:28	AL_U1.Active	28	U1 - Alarm status
OBJECT_BINARY_VALUE:29	AL_U2.Active	29	U2 - Alarm status
OBJECT_BINARY_VALUE:30	AL_U3.Active	30	U3 - Alarm status
OBJECT_BINARY_VALUE:31	AL_U4.Active	31	U4 - Alarm status
OBJECT_BINARY_VALUE:32	AL_U5.Active	32	U5 - Alarm status
OBJECT_BINARY_VALUE:33	AL_U6.Active	33	U6 - Alarm status
OBJECT_INTEGER_VALUE:100	DevicesRotation_Mng.DevPwrOutPerc[0]	100	Unit 1 currently used power in percentual
OBJECT_INTEGER_VALUE:103	Units_bmpDI[1]	103	Unit 1 digital inputs status
OBJECT_INTEGER_VALUE:104	Units_bmpDO[1]	104	Unit 1 digital outputs status
OBJECT_INTEGER_VALUE:105	Units_bmpAlarms1[1]	105	Unit 1 alarms status (block 1)
OBJECT_INTEGER_VALUE:106	Units_bmpAlarms2[1]	106	Unit 1 alarms status (block 2)
OBJECT_INTEGER_VALUE:107	Units_bmpAlarms3[1]	107	Unit 1 alarms status (block 3)
OBJECT_INTEGER_VALUE:108	Units_bmpWarnings[1]	108	Unit 1 warnings status
OBJECT_INTEGER_VALUE:109	Units_bmpExp1[1]	109	Unit 1 expansion 1 I/O status
OBJECT_INTEGER_VALUE:110	Units_bmpExp2[1]	110	Unit 1 expansion 2 I/O status
OBJECT_INTEGER_VALUE:200	DevicesRotation_Mng.DevPwrOutPerc[1]	200	Unit 2 currently used power in percentual
OBJECT_INTEGER_VALUE:203	Units_bmpDI[2]	203	Unit 2 digital inputs status
OBJECT_INTEGER_VALUE:204	Units_bmpDO[2]	204	Unit 2 digital outputs status
OBJECT_INTEGER_VALUE:205	Units_bmpAlarms1[2]	205	Unit 2 alarms status (block 1)
OBJECT_INTEGER_VALUE:206	Units_bmpAlarms2[2]	206	Unit 2 alarms status (block 2)
OBJECT_INTEGER_VALUE:207	Units_bmpAlarms3[2]	207	Unit 2 alarms status (block 3)
OBJECT_INTEGER_VALUE:208	Units_bmpWarnings[2]	208	Unit 2 warnings status
OBJECT_INTEGER_VALUE:209	Units_bmpExp1[2]	209	Unit 2 expansion 1 I/O status
OBJECT_INTEGER_VALUE:210	Units_bmpExp2[2]	210	Unit 2 expansion 2 I/O status
OBJECT_INTEGER_VALUE:300	DevicesRotation_Mng.DevPwrOutPerc[2]	300	Unit 3 currently used power in percentual
OBJECT_INTEGER_VALUE:303	Units_bmpDI[3]	303	Unit 3 digital inputs status
OBJECT_INTEGER_VALUE:304	Units_bmpDO[3]	304	Unit 3 digital outputs status
OBJECT_INTEGER_VALUE:305	Units_bmpAlarms1[3]	305	Unit 3 alarms status (block 1)
OBJECT_INTEGER_VALUE:306	Units_bmpAlarms2[3]	306	Unit 3 alarms status (block 2)
OBJECT_INTEGER_VALUE:307	Units_bmpAlarms3[3]	307	Unit 3 alarms status (block 3)
OBJECT_INTEGER_VALUE:308	Units_bmpWarnings[3]	308	Unit 3 warnings status
OBJECT_INTEGER_VALUE:309	Units_bmpExp1[3]	309	Unit 3 expansion 1 I/O status
OBJECT_INTEGER_VALUE:310	Units_bmpExp2[3]	310	Unit 3 expansion 2 I/O status
OBJECT_INTEGER_VALUE:400	DevicesRotation_Mng.DevPwrOutPerc[3]	400	Unit 4 currently used power in percentual
OBJECT_INTEGER_VALUE:403	Units_bmpDI[4]	403	Unit 4 digital inputs status
OBJECT_INTEGER_VALUE:404	Units_bmpDO[4]	404	Unit 4 digital outputs status
OBJECT_INTEGER_VALUE:405	Units_bmpAlarms1[4]	405	Unit 4 alarms status (block 1)
OBJECT_INTEGER_VALUE:406	Units_bmpAlarms2[4]	406	Unit 4 alarms status (block 2)
OBJECT_INTEGER_VALUE:407	Units_bmpAlarms3[4]	407	Unit 4 alarms status (block 3)
OBJECT_INTEGER_VALUE:408	Units_bmpWarnings[4]	408	Unit 4 warnings status
OBJECT_INTEGER_VALUE:409	Units_bmpExp1[4]	409	Unit 4 expansion 1 I/O status

OBJECT_INTEGER_VALUE:410	Units_bmpExp2[4]	410	Unit 4 expansion 2 I/O status
OBJECT_INTEGER_VALUE:500	DevicesRotation_Mng.DevPwrOutPerc[4]	500	Unit 5 currently used power in percental
OBJECT_INTEGER_VALUE:503	Units_bmpDI[5]	503	Unit 5 digital inputs status
OBJECT_INTEGER_VALUE:504	Units_bmpDO[5]	504	Unit 5 digital outputs status
OBJECT_INTEGER_VALUE:505	Units_bmpAlarms1[5]	505	Unit 5 alarms status(block 1)
OBJECT_INTEGER_VALUE:506	Units_bmpAlarms2[5]	506	Unit 5 alarms status (block 2)
OBJECT_INTEGER_VALUE:507	Units_bmpAlarms3[5]	507	Unit 5 alarms status (block 3)
OBJECT_INTEGER_VALUE:508	Units_bmpWarnings[5]	508	Unit 5 warnings status
OBJECT_INTEGER_VALUE:509	Units_bmpExp1[5]	509	Unit 5 expansion 1 I/O status
OBJECT_INTEGER_VALUE:510	Units_bmpExp2[5]	510	Unit 5 expansion 2 I/O status
OBJECT_INTEGER_VALUE:600	DevicesRotation_Mng.DevPwrOutPerc[5]	600	Unit 6 currently used power in percental
OBJECT_INTEGER_VALUE:603	Units_bmpDI[6]	603	Unit 6 digital inputs status
OBJECT_INTEGER_VALUE:604	Units_bmpDO[6]	604	Unit 6 digital outputs status
OBJECT_INTEGER_VALUE:605	Units_bmpAlarms1[6]	605	Unit 6 alarms status (block 1)
OBJECT_INTEGER_VALUE:606	Units_bmpAlarms2[6]	606	Unit 6 alarms status (block 2)
OBJECT_INTEGER_VALUE:607	Units_bmpAlarms3[6]	607	Unit 6 alarms status (block 3)
OBJECT_INTEGER_VALUE:608	Units_bmpWarnings[6]	608	Unit 6 warnings status
OBJECT_INTEGER_VALUE:609	Units_bmpExp1[6]	609	Unit 6 expansion 1 I/O status
OBJECT_INTEGER_VALUE:610	Units_bmpExp2[6]	610	Unit 6 expansion 2 I/O status
keyname	object-name	object-instance	description
# keyname	object-name	object-instance	description
OBJECT_DEVICE:200	uPC3200	200	CAREL Multitasking Controller
OBJECT_ANALOG_VALUE:1	ManagerHP90_BT1.Val	1	Tank BT1 probe (lowest system temperature) - Value



© Watts Heating and Hot Water Solutions LLC dba Lync by Watts 2026