

Installation, Operation and Maintenance Manual

Lync WQ-AS

Complete Water Quality Solutions

Models:

WQAS-040-C

WQAS-040-S

WQAS-070-C

WQAS-070-S

WQAS-100-C

WQAS-100-S



Disclaimer

The information contained in this document is subject to change without notice from Watts Heating and Hot Water Solutions LLC dba Lync by Watts ("Lync"). Lync makes no warranty of any kind with respect to this material, including, but not limited to, implied warranties of merchantability and fitness for a particular application. Some states do not allow the exclusion or limitation of incidental or consequential damages, so the above limitation may not apply. Lync is not liable for errors appearing in this document, not for incidental or consequential damages occurring in connection with the furnishing, performance, or use of these materials.

Engineered Solutions

IMPORTANT

Read this Manual **BEFORE** using this equipment. Failure to read and follow all safety and use information can result in death, serious personal injury, property damage, or damage to the equipment.

Keep this Manual for future reference.

TABLE OF CONTENTS

SECTION

1. Introduction	4
1.1. System Overview	4
1.2. Specifications	5
2. Lync WQ-AS Components	8
2.1. WQ-AS Skid Components	8
3. Installation and Startup	9
3.1. Pre-Installation Considerations	9
3.2. Installation Location	9
3.3. Plumbing And UV Connections	10
3.4. Electrical Connections	11
3.5. Startup	12
3.6. Operation	12
4. Troubleshooting	13
5. Replacement Part List	14
5.1. Lync Aquasolve Parts	14
5.2. Lync Cartridge Filtration System Parts	15
5.3. Lync UV-H Systems	16
6. Maintenance	17
6.1. Replacing Aquasolve Media	17
6.2. Lync Cartridge Filtration System Filter Replacement	19
7. LYNC UV-H Ultraviolet Water Disinfection System	20
7.1. Important Instructions and Safety Information	20
7.2. System Controls	22
7.3. Lync UV-H Operating Instructions	23
7.4. Troubleshooting	30
7.5. Maintenance	32

1. Introduction

1.1. System Overview

The Lync WQ-AS series of products are complete, fully engineered multi-barrier, packaged systems that optimize your system's water quality by integrating scale prevention, sediment filtration and UV disinfection. Lync WQ-AS products are factory pre-assembled to minimize installation time and labor.

WARNING!

Lync WQ-AS contains a UV-C emitter (UV lamp). Unintended use of the appliance or damage to the housing may result in the escape of dangerous UV-C radiation. UV-C radiation may, even in small doses, cause harm to the eyes and skin. Appliances that are obviously damaged must not be operated. Do not operate the UV-C emitter when it is removed from the appliance enclosure. The appliance must be disconnected from the power supply before replacing the UV-C emitter. **DO NOT** look directly at the UV-C emitter while it is ON. Permanent serious eye injury could occur.

This appliance can be used by people aged from 18 years and above and persons with reduced physical, sensory or mental capabilities or lack of experience and knowledge if they have been given supervision or instruction concerning use of the appliance in a safe way and understand the hazards involved. Children shall not play with the appliance. Cleaning and user maintenance shall not be made by children.

Lync UV-H systems, manufactured by UV Pure technologies, are engineered with the highest quality components. If at any time a component needs to be replaced, use only parts recommended and supplied by Lync.

DO NOT add components to or remove components from this system, except for replacement parts such as UV lamps, filter cartridges, and AquaSolve replacement media.

The UV-H lamps are rated for 12 months for 750P model and 16 months for 1000P model (under normal operating conditions) and should be replaced every 12 months (750P model) and every 16 months (1000P model) to keep the UV intensity at the highest possible output. Quartz sleeves should be cleaned as needed or replaced as needed to guarantee the highest possible UV transmittance into the water. Use only Lync supplied UV lamps and quartz sleeves. Failure to do so may result in system failure and will void all warranty.

DO NOT use this system in a manner that it is not intended for. The UV-H systems are only for use in water applications where the feed water, installation environment and installation method meets the requirements within this manual. The system must be properly sized.

DO NOT exceed the rated flow rate capacity of the system. Follow all product safety labeling. **DO NOT** let the system freeze, as system damage may result. Install the system on a flat, and level surface. The quality of the water to be treated must meet the feed water guidelines within this manual. Failure to ensure proper pretreatment will result in inadequate disinfection.

1.2. Specifications

Lync WQ-AS Systems	WQAS-040-S WQAS-040-C	WQAS-070-S WQAS-070-C	WQAS-100-S WQAS-100-C
Peak flow rate	40 GPM	70 GPM	100 GPM
Number of Lync UV-H systems	1 – 750P	1 – 1000P	1 – 1000P
Number of Lync cartridge housings	1-LCH-150		
Number of Lync filter cartridges	2 (1 spare) LCB-150-P5		
Number of AquaSolve systems	1 (75 GPM)	1 (75 GPM)	2 (75 GPM)
Inlet/Outlet	2" SCH80 PVC Flange		
Operating pressure	28 psi to 125 psi		
Max ambient temperature/humidity	122 °F / 95 % relative humidity (non-condensing)		
Operating temperature	40°F - 100°F (5°C - 38°C)		
Max hardness	30 Grains (513 mg/L as CaCO ₃)		
Max free chlorine	2 ppm		
Max iron	0.3 ppm		
Max manganese	0.05 ppm		
Max copper	1.3 ppm		
Max silica	20 ppm		
Max TDS	1500 ppm		
pH	6.5 – 8.5		
Total phosphate	3 ppm or less		
Oil and H ₂ S	Not allowed		
Dimension W x D x H (inches)	97 x 24 x 81		130 x 24 x 81
Shipping weight	800 lbs (363kg)	830 lbs (376kg)	1200 lbs (544kg)

Lync UV-H	
Min. UVT for 40mJ/cm ² Dose	95 % UVT
Chamber material	316L SS
Input voltage	120VAC, 50/60 Hz
Lamp technology	LPHO Amalgam
Lamp life	12 months 16 months
UV Sensor	Dual Quad
Built in Purge Valve	Standard
Automatic Quartz Sleeve Cleaning	Standard
Wiper Position Switch	Standard
Lamp heaters	Standard -
Modbus Connectivity (4-20mA)	Only -C models
System display type	Color Touch Screen with multiple languages, intuitive screen navigation, detailed system status messages, maintenance/diagnostic, and dealer programmable with website/contact information

Lync Cartridge Filtration System	
Lyne Cartridge Micron Rating	5 micron (nominal)
Cartridge Filter Body & End Cap Material	Glass reinforced PP
Filter housing pressure gauge port	1/4" FNPT
Housing Lid Swing Bolt Material	304SS
O-Ring Material	EPDM
Housing Lid Closure Type	Swing bolt
Pipe fittings (One inlet and two outlets) PVC	2" SLIP Female PVC
Drain	1/2" FNPS with drain plug
Cartridge Replacement Criteria	10 psi differential (max.)

Lync AquaSolve	
Peak Flow rate per AquaSolve	75 gpm
Standard NPT inlet / outlet ports	2" NPT-F / 2"NPT-F

WARNING!

- Not for use on closed loop systems.
- Do not let the system freeze. Damage to the tank may result.
- Place the WQ-AS skid on level surface. Because the system operates in an up-flow, fluidized bed mode, having a level surface is more important than with a softener or media filter.
- A bypass valve should be installed before and after the skid to facilitate installation and service.
- Observe all local plumbing and building codes when installing the system.
- Do not apply any other anti-scalants before or after WQ-AS skid.
- The addition of soaps, chemicals, or cleaners, before or after AquaSolve treatment, may reverse its anti-scale treatment effects and/or create water with a heavy residue or spotting potential. Any adverse conditions caused by the addition of soaps, chemicals, or cleaners are the sole responsibility of the end user.
- AquaSolve is not a water softener and does not soften the water. Water treatment chemistry requires to be compatible with water quality requirements outlined in the specifications table.

Spotting may occur on external plumbing surfaces. AquaSolve media systems perform best in single pass potable water applications with NO additional chemical additives. Depending on hardness, soft scale spotting may occur. Soft scale spots in most cases can be easily wiped down with a damp cloth and will not form hard scale deposits. A Point of Use (POU) Water Softener should be used on mandatory spot-free applications (e.g. glass stemware, dishware).

Water known to have heavy loads of dirt and debris may require pre-filtration prior to WQAS skid. AquaSolve media technology is effective at controlling lime-scale formation inside the plumbing system at influent hardness levels up to 75 grains per gallon (1282 mg/l) of calcium carbonate. Due to variances in water chemistry, 30 grains per gallon is a recommended hardness maximum due to potential aesthetic issues related to soft scale residue formation outside of the plumbing system. Testing should be performed to determine proper application where hardness levels exceed 30 grains per gallon.

Just as with conventional water softening media, AquaSolve media needs to be protected from excess levels of certain metals that can easily coat the active surface, reducing its effectiveness over time. Public water supplies rarely, if ever, present a problem, but if the water supply is from a private well, confirm that the levels of iron (Fe) and manganese (Mn) are less than 0.3 mg/L and 0.05 mg/L, respectively.

Pursuant to the EPA drinking water standards, the copper concentration permitted is up to 1.3 ppm. Typically originating from new copper plumbing, high levels of copper can foul AquaSolve media. For applications with copper concentrations greater than 1.3 ppm, please consult Lync Technical Service. To further minimize any problem with excess copper, avoid applying excessive flux on the inner surfaces of the pipe and use a low-corrosivity water soluble flux listed under the ASTM B813 standard.

AquaSolve media does not reduce silica scaling. While silica tends to have a less significant effect on scale formation than other minerals, it can act as a binder that makes water spots and scale residue outside the plumbing system difficult to remove. This 20 ppm limitation is for aesthetic purposes. All other contaminants must meet the requirements of the USEPA Safe Drinking Water Act. Specific Mineral and Metal MCL's, identified in Lync published Feed Water Chemistry Requirements, supersedes the USEPA SDWA.

Exceeding maximum flow can reduce effectiveness and void warranty. Pressure drop at peak flow rate is less than 28 psi (pressure drop reading taken with inlet and outlet gauges installed at a common elevation and 80 degree feed water).

2. Lync WQ-AS Components

2.1. WQ-AS Skid Components

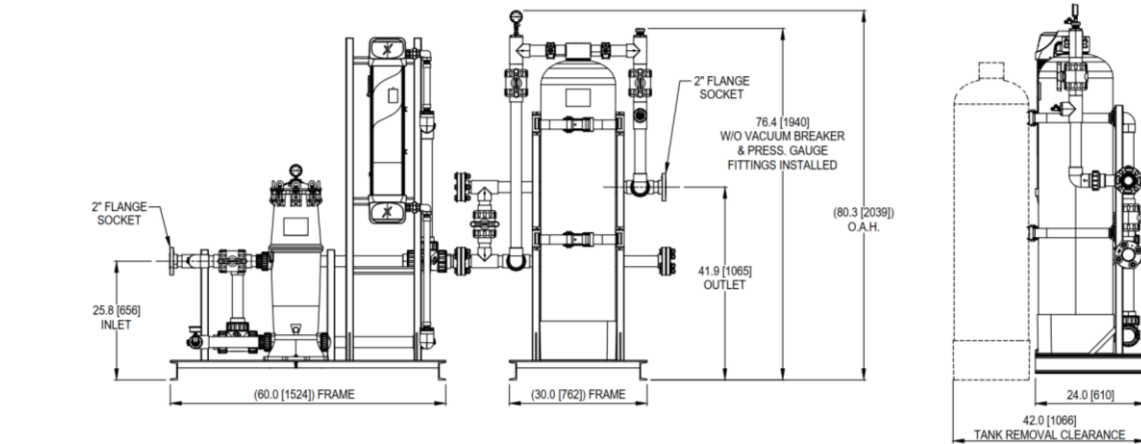

WQAS-040-S/C

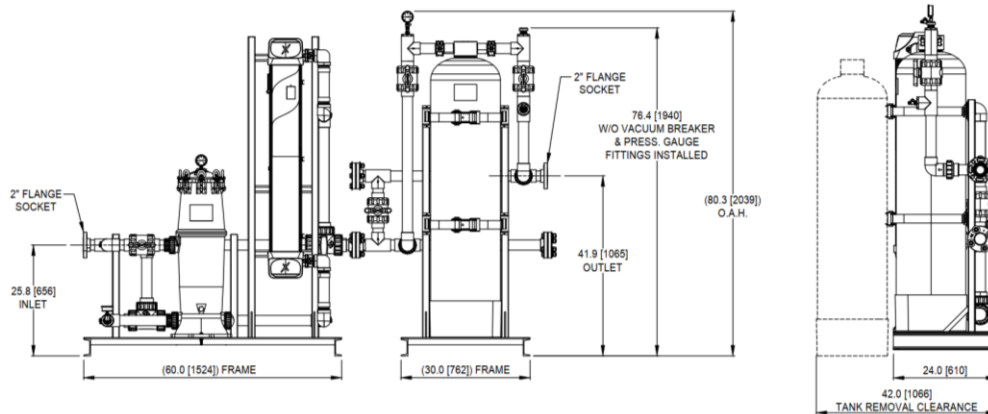

WQAS-070-S/C

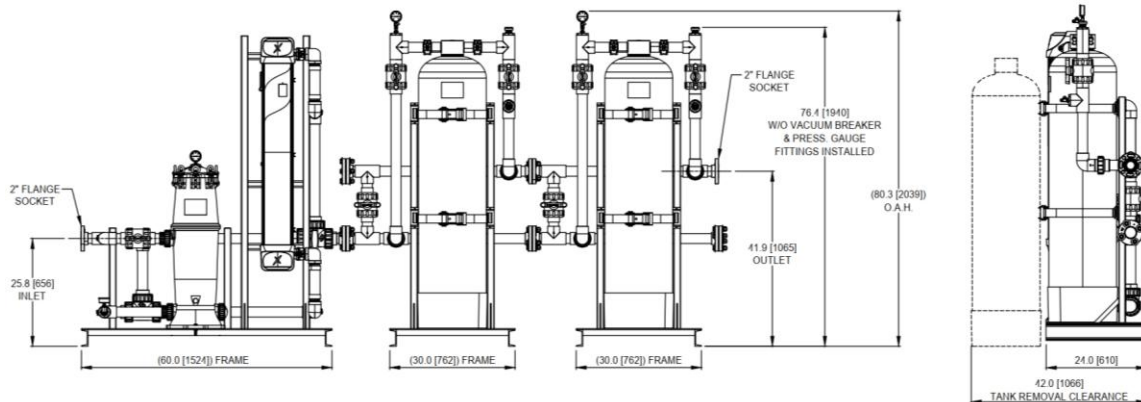

WQAS-100-S/C

Figure 2-1 General WQ-AS Component Identification

3. Installation and Startup

3.1. Pre-Installation Considerations

Unpack the crates and make sure all components are accounted for according to the table below for each specific model. If any components are missing or damaged contact your Lync representative. If they cannot be reached contact Lync customer service at 1-800-433-5654.

Component	Shipped Loose	Pre-installed	Quantity		
			WQAS-040-S WQAS-040-C	WQAS-070-S WQAS-070-C	WQAS-100-S WQAS-100-C
Lync Cartridge Filter Housing		X	1	1	1
Lync UV System		X	1	1	1
Lync AquaSolve System		X	1	1	2
Filter Cartridge		X	1	1	1
Extra Filter Cartridge	X		1	1	1
UV Sensor		X	1	2	2
UV Quartz Sleeve		X	1	1	1
UV Lamp		X	2	2	2
UV Power Cord	X		1	1	1
UV Purge Valve Tubing 20 ft	X		1	1	1
AquaSolve Inlet Sample Port Assembly	X		1	1	2
Vacuum Relief Valve	X		1	1	2
2" Gasket Kit	X		1	1	2
Quartz Sleeve O-Ring		X	1	1	1

3.2. Installation Location

Lync WQ-AS is a complete system with factory pre-assembled plumbing and wiring to minimize installation time and labor. Components are fastened onto a steel skid for safe and easy transportation and installation.

1. Confirm that the system being installed matches the flow rate for the application.
2. The WQ-AS system should be installed as close as possible to the treated water's point of use.
3. Position the system in a suitable location with 48 inches of space around the system to allow for the maintenance. Allow 48 inches of clearance for the removal of quartz sleeve.
4. Responsibility for meeting local electrical and plumbing codes lies with the owner/operator.
5. Install indoors in an area protected from freezing.

NOTES:

- DO NOT install the system near any source of heat. Also, DO NOT install the system near any device or break out area that would be adversely effected by water.
- DO NOT install this system higher in elevation than 10,000 feet above sea level.
- DO NOT install where system is exposed to harsh chemicals or may be subjected to being struck by moving equipment, carts, mops or any other item that may cause damage.
- DO NOT install the system outdoors. Keep system away from moisture, rain, and direct sunlight. Ambient air temperature must remain below 122°F and relative humidity must remain below 95%.

NOTES:

- The system **MUST** be installed in accordance with all applicable national, state and local codes.
- Additional pretreatment may be necessary so that the feedwater conforms to the Feed Water Specifications.
- The skid can be bolted down to the floor, if required.

3.3. Plumbing And UV Connections

It is the responsibility of the end user to ensure that the installation is done according to local codes and regulations. 2" slip-on PVC flanges in inlet and outlet provides the option for both flange and slip connections.

1. Turn off water heater(s).
2. Turn off the main water supply valve to the pipe the system will be installed in.
3. Relieve pressure within plumbing system by opening then closing both the hot and cold sides of a faucet until water ceases to dispense from faucet.
4. If water heater(s) is equipped with isolation valves, isolate the water heater(s) by closing inlet and outlet valves.
5. If no isolation valve exists at system installation location, it is recommended to install an isolation valve located within 10 feet of the system.
6. After finalizing the installation location, place the filter and UV skid in installation location and connect the feed water line to the inlet side of the skid.
7. Place the AquaSolve skid next to filter and UV skid. Use the 2" gasket kit to connect the inlet flange of AquaSolve skid to outlet flange of filter and UV skid.
8. Connect the outlet of AquaSolve skid to treated water line plumbing.
9. Connect the purge valve to a drain using the tubing provided – see Figure 3.1. Note that an air gap is typically required between tubing and drain - follow local plumbing regulations. The tubing can be placed down the back side of the unit. The tubing should be secured to the wall or floor to prevent it from moving during the purging cycle. During startup of the unit, it is strongly recommended to test the purge valve to confirm connections are free of leaks and the water discharges to drain.

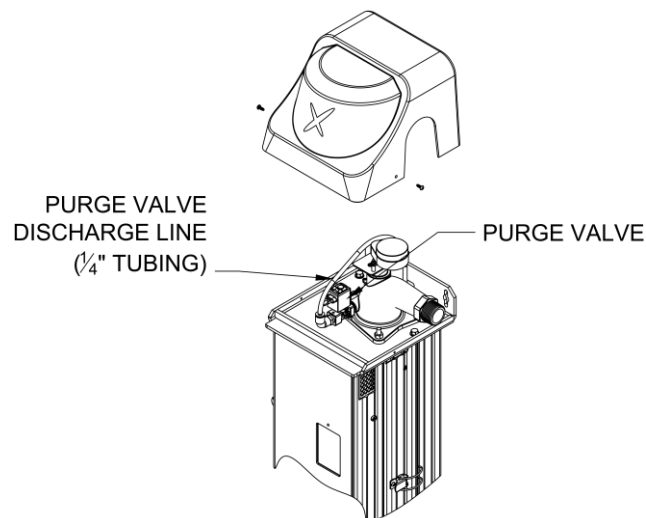

Figure 3-1 Lync UV-H Header Connections

10. Use Teflon tape and install the AquaSolve inlet sample port assembly on the inlet side of the AquaSolve tank (see Figure 3-2).
11. Use Teflon tape and install AquaSolve vacuum relief valve on the outlet side of the AquaSolve tank (see Figure 3-2).

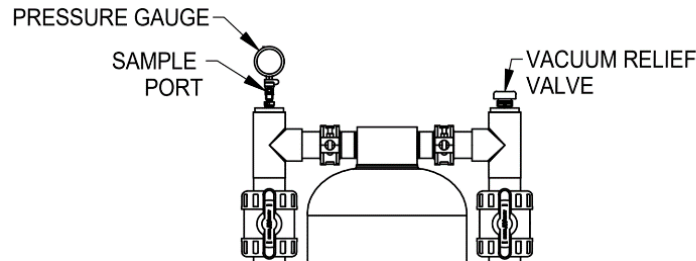

Figure 3-2 WQ-AS AquaSolve Header Connections

NOTES:

- The Lync Cartridge Filtration system is inspected prior to shipment. Before installation, however, check the lid's O ring to ensure it is in place.
- If water hammer is evident, install water hammer arrestors before the system.

3.4. Electrical Connections

It is the responsibility of the end user to ensure that the installation is done according to local codes and regulations. To comply with National Electrical Code, NFPA 70, the circuit where the UV unit is connected must be protected by a ground-fault circuit-interrupter (GFCI). Lync by Watts recommends the use of Hubbell GFCIs for 120Vac.

WARNINGS!

This appliance must be grounded. In the event of a malfunction or breakdown, grounding will reduce the risk of electric shock by providing a path of least resistance for electric current. This appliance is equipped with a cord having an appliance-grounding conductor and a grounding plug. The plug must be plugged into an appropriate outlet that is installed and grounded in accordance with all local codes and ordinances.

Improper connection of the appliance-grounding conductor can result in a risk of electric shock. Check with a qualified electrician or service representative if you are in doubt whether the appliance is properly grounded. Do not modify the plug provided with the appliance; if it will not fit the outlet, have a proper outlet installed by a qualified technician.

3.5. Startup

Once the plumbing and electrical connection procedures are completed, follow the steps below to fill up the systems with water:

- Verify that the UV-H unit(s) is unplugged
- Verify that the outlet isolation valve after the AquaSolve(s) skid is closed
- Verify that the inlet valve to Lync Cartridge Filter is open
- Verify that the inlet valve and outlet valves of the AquaSolve tank(s) are open
- Connect a hose to the outlet sampling valve after the outlet valve of the AquaSolve tanks
- Run the hose(s) to a drain and open the hose bibb(s)
- Slowly/partially open the supply water valve to the WQ-AS skid and allow the Lync Cartridge Filtration system, UV-H and AquaSolve tank(s) to slowly fill with water
- When a stream of water appears at the drain, close the supply valve and hose bibb(s)

Once the fill-up procedure is complete, inspect the system to assure it is free from leaks. After it is verified that there are no leaks, follow the steps below to complete the startup:

- If leaks occur at Lync Cartridge Filtration system, close the inlet isolation valve to the housing, press the pressure release button, remove lid and check that O-ring is properly seated.
- Plug in power cord(s) into an appropriate outlet to start the UV disinfection

NOTES:

- DO NOT allow this system to remain ON without water in it for extended periods of time.
- DO NOT allow the system to freeze.
- Do not operate filter above 125psi (8.8 bar). In installations where pressure is above 100psi (6.9 bar), install a pressure release valve to release pressure at 125psi (8.8 bar) or less.
- A 1/4" FNPT port and pressure gauge has been installed in the filter's lid to indicate working pressure. A second gauge is installed downstream of the filter in the pipe line to indicate pressure differential and help determine when cartridge replacement may be necessary.

WARNING!

Do not attempt to remove the cartridge filter lid without relieving pressure. To open lid, close shutoff valves before and after filter, press pressure relief button to relieve pressure. Once pressure has been relieved, remove swing bolts and lid. To start up filter, replace lid, tighten swingbolts, and open shutoff valves slowly to check for leaks. If lid O-ring does not seat properly, close shutoff valves, relieve pressure, open lid, apply a small amount of non-petroleum based lubricant to the O-ring to help it seal, reposition O-ring and close lid.

Fill in the install date and rebed due date on the product label located on the front of each tank as a reminder to replace AquaSolve media every 3 years. The system is now ready for service.

3.6. Operation

The Lync Cartridge Filtration system and Lync AquaSolve are flow-through systems that operate with no controls and electricity. For Lync UV-H operation, refer to the Lync UV-H manual in Appendix A

4. Troubleshooting

System Status	Possible Cause	Corrective Action
Low pressure after the system	Clogged cartridge	Clean or replace the cartridge
No Power (LED is off, touchscreen is off)	Ground-fault circuit-interrupter tripped.	Check for water leaks. Reset GFCI.
	Fuse Blown.	Check for water leaks. Replace fuse (see Fig. 4.4 for fuse location)
	Touchscreen pcb not connected to power	Ensure ribbon cable connected at both ends.
	Circuit Board is damaged.	Confirm if Power pcb has any illuminated LEDs. If so replace Touchscreen pcb (LCD).
UV Lamps not starting (occurs after 6 unsuccessful attempts)	UV Chamber interlock not engaged.	Check that each latch is correctly positioned and secure UV chamber door.
	# of lamp starts have exceeded specification.	Review Total Lamp starts in System Info Menu. Replace but reduce future lamp cycles.
	UV lamp failure	Replace lamps
	UV Ballast Failure	Replace ballast
	Over temperature condition.	Either system, pcb or water temperature has occurred. Allow to cool off and investigate cause by reviewing Message History.
UV Lamps on but UVI is low	Lamps warming up after power interruption	Allow up to 15 minutes to reach full power
	New LPHO lamps installed.	First time LPHO lamps are turned on it may take 3-4 hours to reach full power. After initial "burn-in", warmup time will be a few minutes.
	UV output of the lamps has diminished.	Lamps have exceeded lifetime; replace lamps.
		# of lamp starts have exceeded specification. Replace lamps but reduce future lamp cycles.
	UV sensor requires recalibration/ replacement.	Install reference sensor to confirm status of unit sensor.
	UV Lamps operating outside of recommended temperature conditions.	Check if UV blower is operating correctly.
For cold water applications, increase room temperature or install LPHO lamp heater kit.		
Water Temperature High Warning & Alarm	Warning issued when water temperature within the UV chamber exceeds 95°F (35°C) for Lync UV-H 1000P and 104°F (40°C) for UV-H 750P. Alarm issued when water temperature within the UV chamber exceeds 113°F (45°C) – UV Lamps are turned off (applies to Lync UV-H 1000P models)	Check if sufficient water pressure to operate purge valve. Check for blockage in purge discharge tubing. Check for debris in purge valve.
System Temperature High Warning & Alarm	The system temperature has exceeded a safe operating level causing the UV lamps to be turned off.	Check if water flow is turned off. Check if operating temperatures have exceeded specifications. Check if both blowers are operating correctly.
Circuit Board Temperature High Alarm	Temperature within electrical chamber has exceeded safe operating level causing UV lamps to turn off.	Check if operating temperatures have exceeded specifications. Check if the pcb blower is operating.
Wiper Not Turning Warning	The system failed to detect wiper motion during routine wiper cycle.	Check wiper motor operation
		Check wiper position switch & cam.

WARNING

All problem conditions called out within this troubleshooting chart require the disinfection procedure to be conducted after the corrective action has been completed (see section 6.4.).

5. Replacement Part List

5.1. Lync AquaSolve Parts

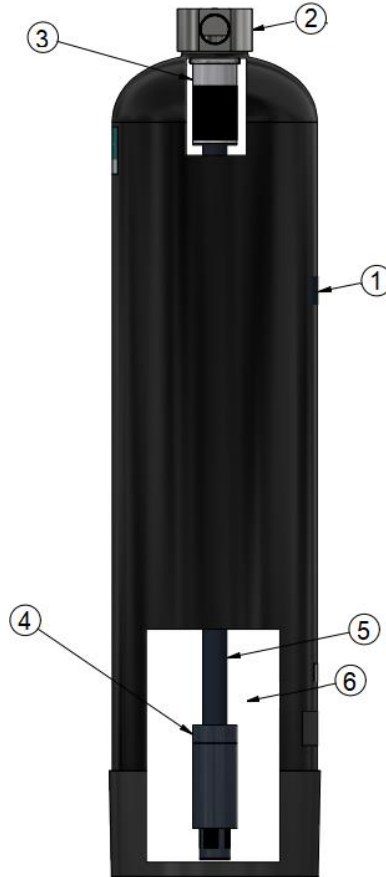

Figure 5-1 AquaSolve Cross Section

Item	Description	Part #
1	Lync AquaSolve Anti-Scale System 75 GPM	158005
2	Lync AquaSolve Tank SS Head	68106656
3	Upper Basket Assembly	68101233
4	1.5" Riser	68103367
5	Bottom Distributor Assembly	68101235
6	Lync AquaSolve Replacement Media	68105665

5.2. Lync Cartridge Filtration System Parts



Figure 5-2 Lync Cartridge Filtration System Parts

Item	Description	Part #
1	LYNC BIG BUBBA HOUSING	68110217
2	BBC-150-P5 CAR BIG BUBBA PLTD 5M	68100632

NOTE:

Cartridge (BBC-150-P5) is cleanable and reusable to reduce costs.



5.3. Lync UV-H Systems

For UV-H parts information, refer to Section 7.5.



Figure 5-3 Lync UV-H

Item	Description	Part #
1	Lync UV-H 750P (WQAS-040-S)	165006
2	Lync UV-H 750P (WQAS-040-C)	165007
3	Lync UV-H 1000P (WQAS-070-S and WQAS-100-S)	165008
4	Lync UV-H 1000P (WQAS-70-C and WQAS-100-C)	165009

6. Maintenance

Maintenance Practice	Frequency
Check for system leaks	Every two weeks
Check the differential pressure* for cartridge replacement	Every two weeks
UV-H lamp replacement for WQAS-040-X	Every twelve months
UV-H lamp replacement for WQAS-070-X and WQAS-100-X	Every sixteen months
Quartz sleeve replacement	Every three years
AquaSolve media replacement	Every three years

* Differential pressure is equal to pressure gauge reading at the inlet side of the filter minus pressure gauge reading at the outlet side of the filter.

Pressure Drop

The Lync Cartridge Filtration System is designed to minimize pressure drop by using 2" pipe fittings and large diameter center tube (see chart below for pressure drop data).

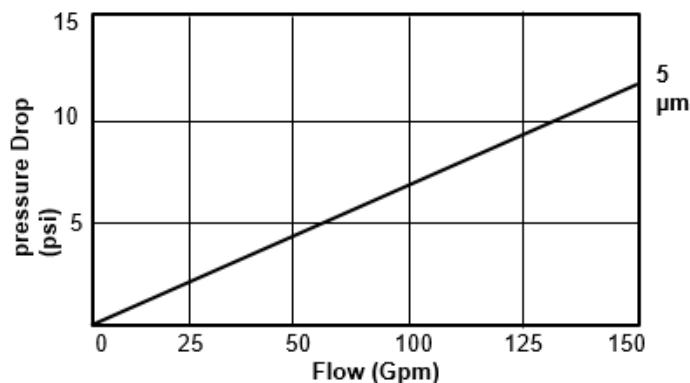

6.1. Replacing Aquasolve Media

1. Shut off the primary feed supply going to the WQ-AS skid.
2. Close the inlet and outlet valves of the AquaSolve(s) to isolate them.
3. Open up the 1/4" drain/sample valve(s) after the AquaSolve outlet valve(s) to release the pressure in the tank and in the distribution lines before and after the AquaSolve(s).
4. Disconnect the unions on the inlet and outlet of the AquaSolve tank head and disconnect flex connectors from head.
5. Using a step ladder and strap wrench, remove the threaded head assembly connection (turning counter-clockwise) and remove complete upper assembly including grey-colored PVC strainer. Rinse these parts in a sink or bucket of water. Do not drain tank.
6. Remove distributor tube with bottom strainer. Rinse parts in a sink or bucket of water.
7. Get a 6 foot length of 3/4" sch. 40 PCV and a length of 1" polyvinyl hose. The length of hose depends on the distance to the nearest floor drain. (Both of these can be acquired at Home Depot or Lowes.)
8. Insert one end of the pipe inside the hose and put the other end of the pipe into the top of the tank and down into the media. Put the other end of the hose inside a rice bag and put the rice bag on the floor drain.

9. Get a garden hose and put it on the open end of the poly hose to fill the hose and pipe with water. Air will bubble out of the tank. Once all the air is out of the hose and pipe, you can start a siphon to remove the media. Put the garden hose in the top of the tank and turn it on to keep the tank full of water. Push the pipe up and down in the media to get it all out. The rice bag will catch the media and allow the water to go down the drain.
10. Try not to be too aggressive when extracting the media. You need to take it out in small amounts. If you let the whole pipe/ hose fill with media it will plug up. Allow water to flush out the pipe / hose as you go to keep from clogging.

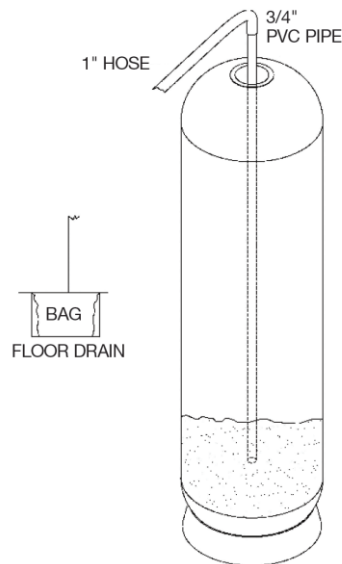

Figure 6-1 Replacing AquaSolve Media

11. When all the old media is removed turn off the garden hose and continue to siphon until the tank is about half full with water.
12. Using the step ladder again, reinstall the distributor tube with bottom strainer that was removed in Step 6. Center the distributor tube in the bottom of the tank. Keeping any and all media from entering the distributor tube, carefully pour-in a new bag(s) of media (see AquaSolve media part number in section 5.1).
13. Inspect the threaded connection on the top of the tank to ensure no loose beads of media are stuck to the internal threads. If visible, wipe away the beads with a damp cloth.
14. Re-attach the head assembly to the distributor tube and thread the assembly back onto the tank. Hand-tighten until a strap wrench can help tighten the connection.
15. Reconnect the flex connectors and union connections.
16. Open the feed water inlet (slowly) to fill the tank.
17. Purge the air at a downstream faucet close to the system.
18. Once the tank is full, wait 4 hours for media to “hydrate”.
19. Put the tank in service.

6.1.1. Alternative Method for Replacing Media

Follow steps 1 – 6 then:

- Remove center distributor tube and lower basket and siphon all water from tank

- Lay tank down on its side and tip upside down while using hose to flush media out
- When all the old media is removed, stand tank back up and install in original position. Fill the tank so that it is about half full with water.

Then continue with steps 12 – 19.

6.2. Lync Cartridge Filtration System Filter Replacement

The Lync filter cartridge needs to be cleaned or replaced with a new cartridge at the maximum of 15 psi differential pressure.

1. Close inlet valve.
2. Close outlet valve.
3. Press pressure relief button to relieve pressure.
4. Remove lid after pressure has been relieved.
5. Rotate cartridge counterclockwise and pull upward to remove the cartridge.
6. Install new (or cleaned) cartridge. Push downward and rotate clockwise to engage locking tabs. Lubricating O-rings if necessary.
7. Check lid O-ring to ensure it is properly seated . Lubricate if necessary .
8. Replace lid.
9. Replace swing bolts and tighten. (Hand tight is sufficient.)
10. Open outlet pipe completely.
11. Open inlet pipe slowly to check for leaks.
12. Vent filter to dispel air by depressing pressure relief button. Be careful when relieving pressure or dispelling air if high temperature water is being filtered.

NOTE: If leaks occur, close the inlet and outlet pipes and follow procedures previously described under WARNING in Section 3.3: Plumbing and UV Connections.

7. LYNC UV-H Ultraviolet Water Disinfection System



7.1. Important Instructions and Safety Information

When operating the UV-H unit, basic precautions should always be followed to reduce the risk of fire, electric shock, and injury to persons, including the following:

1. Read all the instructions before installing or operating the system.
2. Pay attention to all warning and caution statements, and also safety symbols throughout these instructions. Failure to do so may result in personal injury and/or damage to equipment.
3. This unit is not intended for use by persons (including children) with reduced physical, sensory or mental capabilities, or lack of experience and knowledge, unless they have been given supervision or instruction concerning use of the unit by a person responsible for their safety.
4. Do not contact moving parts.
5. Only use attachments or spare parts recommended or sold by Lync by Watts.
6. The unit is intended only for indoor use in a dry location.
7. Do not unplug the unit by pulling on cord. To unplug, grasp the plug, not the cord.
8. Unplug the unit from the outlet when not in use and before any servicing or cleaning.
9. The UV chamber contains an interlock to disable the UV lamps if the event the chamber is accessed when the power is on. Do not defeat its purpose or attempt to service without opening the panel completely.
10. Do not operate the unit with a damaged cord or plug, or after a significant malfunction or is dropped or damaged in any manner. Return the unit to the nearest authorized service facility for examination, repair, or electrical or mechanical adjustment. If the supply cord is damaged, it must be replaced by a special cord available from Lync.
11. Connect the unit only to a circuit that is protected by a ground-fault circuit-interrupter (GFCI). See Grounding Instructions.
12. If an extension cord is necessary, the cord should contain a ground and be rated for the same amperage as the unit or combined units.
13. Do not plug in unit if water is present on the unit or if any nearby piping connections are leaking.
14. Service to the unit does not require the removal of the endplates, they must remain assembled.
15. In the event of an alarm or shut down of the UV unit and water continues to flow either accidentally or for emergency purposes, or if the UV system is bypassed, it is recommended that any water used for drinking be boiled.
16. Do not operate the unit dry.
17. Do not operate this unit at altitudes over 3000m.
18. If the unit is installed in a room storing chemicals or is exposed to unnatural substances such as hydrogen sulfide, the room must be ventilated.

7.1.1. Grounding Instructions

This UV unit must be grounded. In the event of a malfunction or breakdown, grounding will reduce the risk of electric shock by providing a path of least resistance for electric current. This unit is equipped with a cord having an appliance-grounding conductor and a grounding plug. The plug must be plugged into an appropriate outlet that is installed and grounded in accordance with all local codes and ordinances. The piping connected to the UV unit must also be properly grounded. Install a grounding lug or strap as required.

WARNING! For correct operation it is essential to observe the manufacturer's instructions.

WARNING! Improper connection of the equipment-grounding conductor can result in a risk of electric shock. Check with a qualified electrician or service representative if you are in doubt whether the unit is properly grounded. Do not modify the plug provided with this unit; if it will not fit the outlet, have a proper outlet installed by a qualified technician.

WARNING! If connected to a potable water system, the system must be protected against backflow.

7.1.2. Ground-Fault Circuit-Interrupter

To comply with National Electrical Code, NFPA 70, the circuit where the UV unit(s) is connected must be protected by a ground-fault circuit-interrupter (GFCI). Lync by Watts recommends the use of Hubbell GFCIs for 120Vac.

7.1.3. Safety Symbols



WARNING: Potential Shock Hazard - Shutdown and unplug the unit before servicing.



DANGER: Ultraviolet Radiation - Disconnect power before replacing lamps. The lamps in the unit emit ultraviolet (UV) light that can damage the skin & eyes. Never look at the lamp when it is operating. Do not plug the unit in unless it is properly installed and all the panels are closed and secured. Do not open a panel or perform any service unless the unit has been unplugged. Never look into the unit or place any exposed skin into the illuminated areas when it is operating. Do not operate a unit that has been damaged or missing any components or safety devices. If a part is missing from your unit, contact your dealer.



CAUTION: Safety Alert - Pay attention to the instructions.



CAUTION: UV Lamps Contain Mercury - UV lamps are fragile and must be handled with care. If breakage occurs, avoid inhalation or ingestion of debris and avoid exposure to skin and eyes. Do not use a vacuum cleaner or broom for cleanup. Follow local guidelines and regulations to remove and dispose of old UV lamps or mercury debris.



CAUTION: Wear appropriate safety equipment - Wear safety glasses when performing maintenance on the unit. For non-potable applications, do not handle wetted parts with bare hands - use latex or vinyl gloves or equivalent.



CAUTION: Quartz sleeves are fragile The quartz sleeve can break or chip if mishandled. Always handle with care and keep it in a safe place if removed from unit. Do not strike the quartz sleeve with any tool, since even the smallest chip can cause it to break under pressure.

7.2. System Controls

7.2.1. Control Interfaces

WARNING: Shutdown and unplug the unit before installing any external wiring.

External wiring can be introduced through the left side of the unit. By default, a plug is installed into this port in a standard unit and a strain relief can be purchased if connection to remote devices is required. For External Contacts and Remote Start/Stop, 20 gauge wire is recommended and if the 4-20mA option is used, 20 gauge wire with foil and drain wire. Install wires onto spring cage terminals provided.

7.2.2. External Contacts

All UV-H systems provide two “dry” contacts for remote alarms or auto-dialers – the word “dry” indicates no voltage present at the contact. The first contact labeled RUN is a “System Run” condition – when closed, the unit is treating; if the contact is open, the unit is in alarm, has lost power, or perhaps the wire has been cut. The second contact labeled WARNING is to indicate the existence of an abnormal condition such as high water temperature. When this contact is open, the system is normal; when this contact is closed, a warning condition exists. Both contacts are meant for control purposes only, not to drive devices. The maximum rating of the contact is 24 Vac or Vdc, 2A.

7.2.3. Remote Start/Stop

All UV-H systems have remote start/stop capability which allows them to remain idle without operating the UV lamps. When a signal is given (voltage applied), UV lamps are energized. This is convenient for locations requiring periodic disinfection such as pump houses. The voltage rating range of the contact is 5-24 Vdc or Vac, 0.5W max. The remote start/stop is disabled by default and can be enabled in the Advanced Settings menu.

Caution: Avoid continuously starting and stopping the unit within a 24 hr period, as this will accelerate aging of the UV lamps and is covered under warranty.

7.2.4. 4-20mA & Modbus Option

A 4-20mA option is available with two continuous analog output signals and one input signal. The output signals can be UV Dose, or UV Intensity, or UV Transmittance. The input signal is flow (on 1000 models only). Modbus capability will also be available when the 4-20mA option is purchased.

7.2.5. Data Logging on USB Option

Data logging capability is an available option on all UV-H units. A small USB drive is used to record system performance every 30 seconds. The USB drive can store up to 4 years’ worth of daily records.

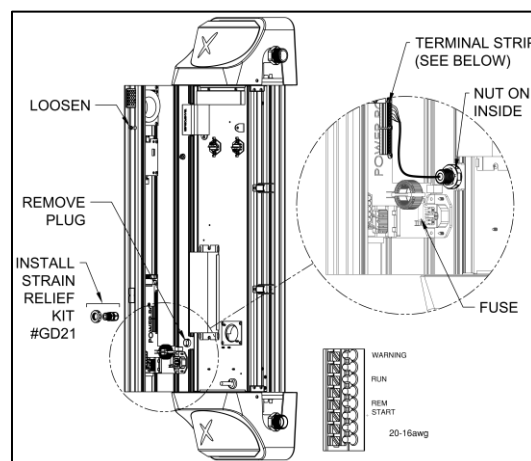

Figure 7-1

7.3. Lync UV-H Operating Instructions

The UV-H applies advanced Crossfire Technology yet is simple to operate. The automatic quartz sleeve cleaning technology available on most models has been designed to reduce, and in most cases, eliminate the periodic shutdowns necessary to inspect the cleanliness of the quartz sleeve. The only required maintenance is the replacement of the two UV lamps.

The unit should be operated with both top and bottom plastic covers installed.

7.3.1. Unit Functions

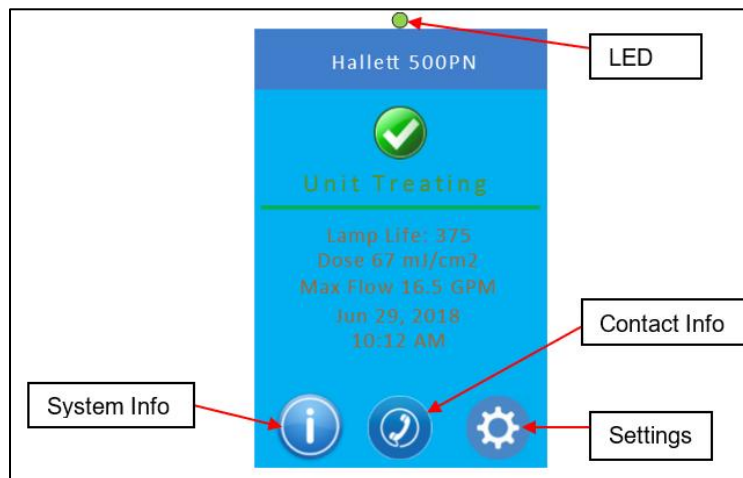

Figure 7-2

The user interface consists of a color touchscreen and a single multi-color LED. The LED will always be illuminated when the UV unit is plugged in and powered up. The touchscreen enters sleep mode after 10 minutes and requires the user to touch it to wake it up. The touchscreen will change colors if any significant event occurs such as warnings or alarms. See the section on Navigating the Menus for a complete layout of the screens.

Indicating LED

Green Light – an illuminated green light indicates the unit is treating normally. A slow flashing green light means the UV lamps are not yet at full power or the unit is in standby mode awaiting a remote start. A fast flashing green light means the wiper is cycling.

Red Light – an illuminated red light indicates either a warning or an alarm has occurred. A warning is a condition that, if not addressed, could impact the unit's performance. Warnings should be addressed as soon as possible. Warnings are accompanied with a flashing red LED, a single beep, a message, and a yellow screen. An alarm is a condition that has significantly impacted the unit's performance and it must be addressed immediately. Alarms are accompanied with a solid red LED, continuous beeping, a message, and a red screen.

Audio Alarm

The audio alarm or beeper, will alert the operator to any conditions out of the ordinary. A single beep will sound if a warning occurs; continuous beeping will sound if an alarm occurs. The audio alarm may be disabled temporarily or permanently in the Settings Menu, item 2.3. The sound level of a unit operating normally is less than 70db(A). However, sound levels can exceed 85 db(A) with the audio alarm on.

7.3.2. Navigating the Menus

- 0** Home
 - 0.1 Model name
 - 0.2 Treatment Status
 - 0.3 Lamp Life
 - 0.4 UV Dose
 - 0.5 Max Flow or Flow Signal (Optional)
 - 0.6 Date & Time

- 0A** Contact Info
 - Text: Company, Phone, Installation date

- 1** System Info
 - 1.1 UVT
 - 1.2 UVI
 - 1.3 Left Lamp UV
 - 1.4 Left Water UV
 - 1.5 Right Lamp UV (If available)
 - 1.6 Right Water UV (If available)
 - 1.7 PCB Temp
 - 1.8 Sys Temp
 - 1.9 Water Temp
 - 1.10 Lamp Temp
 - 1.11 Wiper Countdown
 - 1.12 Daily Starts
 - 1.13 Firmware Version
 - 1.14 Total Starts
 - 1.15 Power-ups
 - 1.16 Life-time counter
 - 1.17 CH1 - Analog Output
 - 1.18 CH2 - Analog Output

- 2 Settings
 - 2.1 Date & Time
 - 2.2 Power Down
 - 2.3 Audible Alarm
 - 2.4 Units (Imperial/Metric)
 - 2.5 Reset Lamp Counter
 - 2.6 Message History (Last 100 messages)
 - 2.6.1 {Message 1}
 - 2.6.1.1 UV Dose
 - 2.6.1.2 Water Temp
 - 2.6.1.3 Estimated UVI
 - 2.6.1.4 Estimated UVT
 - 2.6.1.5 Left Lamp UV
 - 2.6.1.6 Left Water
 - 2.6.1.7 Right Lamp UV
 - 2.6.1.8 Right Water
 - 2.6.1.9 Lamp Temp
 - 2.6.2.0 PCB Temp
 - 2.6.2.1 System Temp
 - 2.6.2 {Message 2}
 - 2.6.3 ...

- 2.7 Advanced Settings
 - 2.7.1 Force Outputs
 - 2.7.1.1 Lamps
 - 2.7.1.2 Wiper
 - 2.7.1.3 Purge Valve
 - 2.7.1.4 Shutoff Valve
 - 2.7.1.5 Fan UV
 - 2.7.1.6 Fan PCB
 - 2.7.1.7 Warning Contact
 - 2.7.1.8 Run Contact
 - 2.7.1.9 Buzzer
 - 2.7.1.10 Heaters
 - 2.7.1.11 C1-4-20mA signal
 - 2.7.1.12 C2-4-20mA signal
 - 2.7.1.13 Interlock for UV door
 - 2.7.1.14 Wiper Positioner switch
 - 2.7.1.15 Remote Start/Stop Signal
 - 2.7.1.16 Fault 1
 - 2.7.1.17 Fault 2
 - 2.7.1.18 Lamp Temp
 - 2.7.1.19 Water Temp
 - 2.7.1.20 Analog In
 - 2.7.1.21 System Temp
 - 2.7.1.22 PCB Temp
 - 2.7.1.23 DC Volts
 - 2.7.1.24 L Lamp Sensor
 - 2.7.1.25 L Water Sensor
 - 2.7.1.26 R Lamp Sensor
 - 2.7.1.27 R Water Sensor
 - 2.7.1.28 CAL - L Lamp
 - 2.7.1.29 CAL - L Water
 - 2.7.1.30 CAL - R Lamp
 - 2.7.1.31 CAL - R Water
 - 2.7.2 Remote Start
 - 2.7.3 Shutoff Valve
 - 2.7.4 Set Defaults
 - 2.7.5 Language
- 2.8 Password for Advanced Menus

Typical message screens shown below:

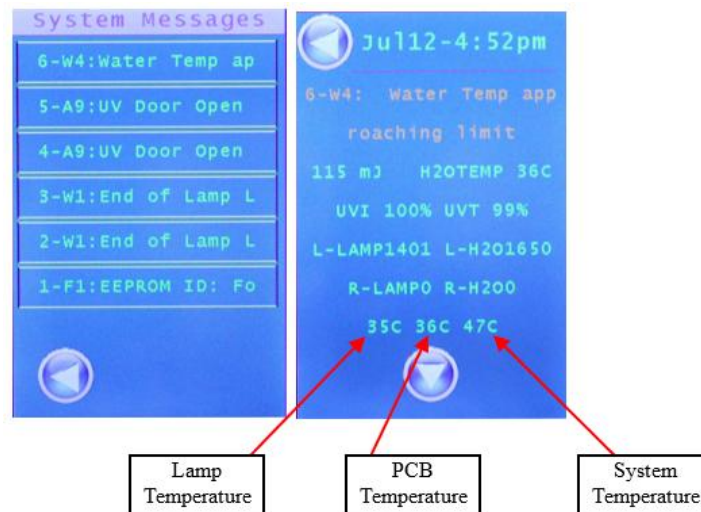

Figure 7-3

7.3.3. Plugging in the UV-H for the first time

1. Ensure all external wiring is complete and all panels are closed before connecting the power cord.
2. Plug female end of power cord into power entry module located on left side of the front panel. Plug the male end of the power cord into a ground-fault circuit-interrupter (GFCI).

CAUTION! Avoid continuously starting and stopping the unit within a 24 hr period, as this will accelerate the aging of the UV lamps and void warranty. See Product Specification Table for permissible lamp cycles.

CAUTION! There must be water in the treatment chamber to prevent damage to internal components.

In the event of a lack of water or water supply being turned off, shutdown the unit until the water supply can be restored. In the event of a power failure, the unit will shut down and the optional solenoid valve will close, preventing water from flowing. When the power returns, the unit will automatically restart and perform a self-test. If no faults are detected, the unit will return to normal operation and the optional solenoid valve will open. Note: even during a brownout, supply voltage may drop low enough to shut down the unit. If the unit does not automatically restart as described above, shutdown and unplug the unit and plug it in again.

3. Once the unit is plugged in, the LED illuminates, an audible tone is issued and the display becomes active to confirm all three devices are functional. The unit then performs a self-diagnostic. Enter the date of installation in the Settings Menu and treatment parameters, if required.
4. When the UV Lamps have started, (lamp ignition for amalgam lamps may take up to 30 seconds) the unit will wait at 10 - 15 minutes depending on the model to allow the lamps to stabilize before transitioning into Treating mode. This will occur every time the UV lamps are powered up. During this warm up, the green LED will flash, the unit will display the countdown to startup, and the optional shutoff valve will remain closed. **New LPHO lamps may take from a few moments to several hours to reach full power. Continue to operate the unit until the lamps reach full power – this may last 24 hours. It is recommended for new LPHO lamps to be operated initially 3-4 hours as a burn-in to achieve lamp stability.** When the warm up process is complete, a solid green light appears and the message “Unit Treating” will be displayed. The optional solenoid valve will be allowed to open only if treatment levels are adequate, otherwise it will remain closed. This is the normal operating mode of the unit.

5. If a power outage occurs, upon return of the power, the unit will start up automatically and perform a diagnostic check. After a 10-15 minute stabilization period, the unit will begin treating if treatment levels are adequate, otherwise an alarm will be issued if the unit is not treating.
6. Test wiper motor and purge valve - see *Advanced Settings menu, items 2.7.1.2 and 2.7.1.3.*
7. Operator should adjust maximum flow setting if required.

7.3.4. Flushing Instructions

Flushing the system is required after installation or after any disassembly and cleaning. Flushing may also be required to remove colored or contaminated water from the unit. Most filters (if installed) also require flushing prior to use – follow the manufacturer’s recommendations.

The system may be flushed manually by disassembling the unit and filling and draining the unit by hand (see In-place Cleaning section). Flushing may also be done while the unit is operating. Plug in the unit and open a tap closest to the unit and have the water flow for at least 15 minutes.

7.3.5. Shutting Down of Unit and Seasonal Use

To shut the unit down, initiate the Power Down procedure located as the second item in the Settings Menu. When this procedure is complete, simply unplug the unit.

The UV-H can operate for extended periods of time without water usage as long as pressurized water is present to allow for purging. The unit may be shut down in the case of seasonal residences or during a vacation. If the possibility of freezing exists, the unit and any valves and filters must be drained. (See Draining the Unit section.)

7.3.6. Disinfecting the Plumbing

Disinfection of the household or facility plumbing should be performed after the UV-H has been installed and is operating. This procedure should also be done if the unit is not functioning normally; if a bypass has been used; or if there has been a high background bacteria count in a water sample. Lync by Watts has found that disinfecting the plumbing is the best way to treat any potential bacteria or contaminants in the distribution system prior to system use.



Please note that this procedure is ineffective against protozoa that can be found in surface water or shallow wells under the influence of surface water. Under these circumstances, it is important to perform the disinfecting procedure and then operate the UV-H. Lync by Watts has found that this procedure does not work with sediments or heavy biofilm and encrustations, which must be removed mechanically.



Lync by Watts recommends sanitizing the household or facility plumbing by adding 50 ppm chlorine from bleach for 12 hours and then flushing. This can be achieved by:

1. Shutdown and unplug the unit.
2. Shut off the water supply and relieve the water pressure by opening a tap.
3. Remove the filter from its housing and fill the housing with bleach
4. Re-mount the housing (but not the filter) and plug in the unit to turn it on.
5. Once unit is operating, turn on the water supply and have the water flow to all taps (hot and cold), toilets, the washing machine and other water-using appliances – the bleach must fill every inch of plumbing. The Dose Alarm may arise due to low UVT after the introduction of bleach. If this occurs, use the manual override on the optional solenoid valve to keep valve open during procedure. Return override to auto position afterward.

6. When you detect the odor of chlorine at each spot, turn off the water and let the bleach remain in the lines for at least 12 hours. Turn off UV unit during this time.

CAUTION! Do not allow corrosive chemicals to remain in the unit for more than 12 hours – Do not operate unit during this time period as heating the water will increase corrosive nature of chemicals.

7. After the waiting period is over, plug in the unit. Once stable, flush every line for at least five minutes or until the odor of chlorine is gone. See local regulations for proper disposal of chlorine residual, especially in the case of discharge into a septic system.
8. Now that the disinfection procedure is complete you will need to return the filter to its housing. Shut off the water supply, relieve water pressure by opening a tap, and return the filter to the housing. Allow a few days after a disinfection procedure before getting a sample since residual chlorine may affect the results.
9. Have the water tested by a local recognized testing agency prior to any water consumption. Lync partners with water testing organizations in select locations throughout North America. Contact Lync for potential water testing partners: (800) 433-5654 (ext. 3). The testing should be performed on a regular basis as required by local regulations.

7.3.7. Automatic Quartz Sleeve Cleaning Device

The self-cleaning feature of the UV-H system involves a wiper turning inside the quartz sleeve. The wiper operates soon after power up of the lamps and then every 4 hours it will cycle for 5 minutes. The wiper can be enabled anytime in the Advanced Settings menu, item 2.2.1.2. The LED will flash quickly during a wiper cycle.

7.3.8. Built in Purge Valve

The UV-H contains a flushing or purge valve that cycles water through the unit during long periods of no water usage. The unit monitors water usage by measuring the rise in water temperature within the treatment chamber. During periods of no water flow, the purge valve on the small units can expel 1 gallon (4 liters) of water every 60-90 minutes; the largest unit can expel up to 4 gallons (15 liters). If the largest unit fails to purge and the water temperature exceeds 113°F (45°C), the unit will shut down to prevent overheating.

7.4. Troubleshooting

If an alarm occurs, the solenoid valve (optional) will close, preventing water from flowing; the LED turns red; the audio alarm will beep continuously; the touchscreen turns red and displays a message; the RUN contact will open to indicate the unit is no longer treating. The fault should be corrected to return the unit to normal operation and have the water flow again.

If a warning occurs, the solenoid valve (optional) remains open; the LED flashes red; the audio alarm will beep once; the screen turns yellow and displays a message; the warning contact will close to indicate the unit is still treating but in an abnormal state. The warning should be addressed as soon as possible and if left unattended, could turn into an alarm.

The Message History, available in the Settings menu, item 2.6, is very useful in troubleshooting since it contains up to 100 messages/events with associated recorded data such as times, UVI, UVT, UV sensor values, and temperatures.

In the event of an alarm, in many cases, a physical inspection of the unit with the power off should be done to try to identify a cause. A slow water leak for instance, near the top of the unit could stain lamps or reflectors and may not be uncovered without a full system inspection.

Dose Alarm

The Dose Alarm occurs when there is insufficient UV dose to treat the maximum flow rate prescribed by the unit. The Dose Alarm could be a result of low UV intensity or low UV Transmittance (UVT) or a combination of both. Review both values in the System Info Menu to determine which is causing the alarm and take corrective action. It is highly recommended to have a UVT sample taken to confirm system prediction.

The Advanced Settings menu under Force Outputs provides the ability to manually turn on and off devices to confirm their operation. Devices return back to their automatic position after 10 minutes.

Cycling the power is also useful to occasionally reset the software.

Troubleshooting Guide

System Status	Possible Cause	Corrective Action
No Power (LED is off, touchscreen is off)	Ground-fault circuit-interrupter tripped.	Check for water leaks. Reset GFCI.
	Fuse Blown.	Check for water leaks. Replace fuse (see Fig. 4.4 for fuse location)
	Touchscreen pcb not connected to power pcb.	Ensure ribbon cable is connected at both ends.
	Circuit Board is damaged.	Confirm if Power pcb has any illuminated LEDs. If so replace Touchscreen pcb (LCD).
UV Lamps not starting after 6 unsuccessful attempts	UV Chamber interlock not engaged.	Check that each latch is correctly positioned and secure UV chamber door.
	# of lamp starts have exceeded specification.	Review Total Lamp starts in System Info Menu. Replace lamps but reduce future lamp cycles.
	UV lamp failure	Replace lamps
	UV Ballast Failure	Replace ballast
	Over temperature condition.	Either the system, pcb or water temperature has occurred. Allow to cool off and investigate cause by reviewing Message History.
UV Lamps on but UVI is low	Lamps are warming up after a power interruption.	Allow lamps up to 15 minutes to reach full power
	New LPHO lamps installed.	First time LPHO lamps are turned on it may take 3 to 4 hours to reach full power. After this initial "burn-in", warmup time will be a few minutes.
	The UV output of lamps has diminished.	Lamps have exceeded lifetime. Replace lamps.
		# of lamp starts have exceeded specification.

	UV sensor requires recalibration/replacement.	Install reference sensor to confirm status of unit sensor.
	UV Lamps operating outside of recommended temperature conditions.	Check if UV blower is operating correctly. For cold water applications, increase room temperature or alter LPHO lamp heater settings.
Water Temperature High Warning & Alarm	Warning issued when water temperature within the UV chamber exceeds 95°F (35°C) for H1000XX and 104°F (40°C) for H400-H750XX. Alarm issued when water temperature within the UV chamber exceeds 113°F (45°C) – UV Lamps are turned off (applies to UV-H 1000W and 1000R and 1000P models)	Check if sufficient water pressure to operate purge valve. Check for blockage in purge discharge tubing. Check for debris in purge valve.
System Temperature High Warning & Alarm	System temperature has exceeded safe operating level causing UV lamps to turn off.	Check water flow. Check operating temperatures. Check system blowers are operating correctly.
Circuit Board Temperature High Alarm	The temperature within the electrical chamber has exceeded a safe operating level causing the UV lamps to be turned off.	Check if operating temperatures have exceeded specifications. Check if the pcb blower is operating.
Wiper Not Turning Warning	System failed to detect wiper motion during routine wiper cycle.	Check wiper motor operation Check wiper position switch & cam.

7.5. Maintenance

Disinfection of water will occur as long as the unit is properly maintained with genuine parts in accordance with these instructions. Operating a malfunctioning unit or defeating any system sensors may jeopardize the safety of the water. Online videos are available to help with typical maintenance tasks. Simple tasks such as quartz inspections and lamp replacements can be done by end-user. More in-depth activities such as quartz replacement, should be done by authorized service representatives.

Test Shutoff Valve Monthly

The optional solenoid shutoff valve should be tested monthly. Unplug valve from unit to confirm water stops flowing. Plug the valve in again to confirm water continues to flow.

Clean Air Filter Periodically

The UV-H contains a washable air filter in the located at the air inlet port (See Figure 7.4). Periodically check and clean the filter to ensure blower operation is not impeded.

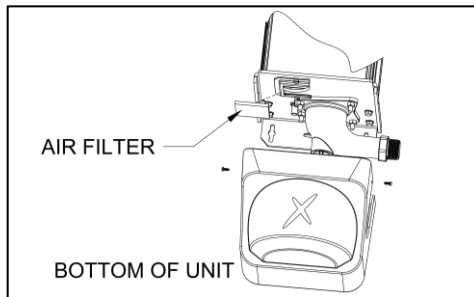

Figure 7-4

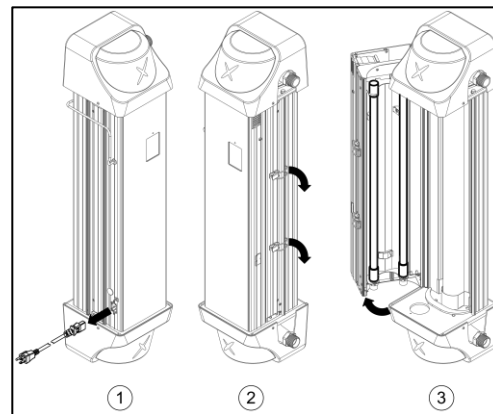

Figure 7-5

Accessing the UV Chamber



The UV chamber can easily be opened for lamp replacement or quartz sleeve inspection without having to drain the unit and without any tools.

CAUTION! Always shut down and unplug the unit before accessing the UV chamber.

1. Shutdown and unplug the unit then wait 5 minutes before opening the UV chamber to allow the lamps to cool. The lamps heat up after use and can burn your skin if touched.
2. See Figure 7-2. Open the UV Chamber by undoing the over-the-center latch. Note where the latch wire engages the extrusion feature – it must be re-latched in same manner.
3. Slowly swing the door completely to the left to reveal the two UV lamps installed in the front half of the UV chamber. Note that the quartz sleeve can be easily inspected.
4. To close the UV chamber, swing the door back towards the back half of the UV chamber. Close all over-the-center latches ensuring the wire correctly grabs the extrusion feature.

Replacing and Cleaning UV Lamps

The UV-H contains two ultraviolet (UV) lamps that emit high-intensity UV light in the germicidal range, providing effective disinfection of the water flowing through the unit. The lamps in the unit will decay over time and they should be replaced every 12 or 16 months for optimum performance – see Product Specification Tables for lamp lifetimes. Note that lamps will only decay while in operation. Shutting down the system for seasonal use will extend lamp life.

The unit has an internal timer to keep track of the lifetime of the lamps. The UV-H will issue a warning when the end of lamp lifetime approaches and it will warn again when the lamp lifetime is exceeded. The amount of life remaining on the lamps is measured in days and can be seen in the Home menu.

CAUTION! Do not allow water to flow until new lamps have been installed and reach full power.



Never touch the bulb (quartz portion) of a lamp. Handle the lamp by its ends only. If the surface of the lamp becomes dusty or dirty, use a clean lint-free cloth and rubbing alcohol. For more difficult stains such as water spots, use a scale remover and rubbing alcohol to remove the stain.

NOTE: Resetting Lamp Lifetime counter will clear Lamp Starts counter and Power Ups counter. If this information is required, review it first before proceeding to Step 1.

1. Open the UV chamber as described above.
2. Use a slotted screwdriver to pry the lamps up between lamp base and ceramic socket, see Figure 7.3
3. When the bottom pins have disengaged the socket, lift the lamp up, then swing the lamp base away from socket. Lower the lamp to disengage it from the top lamp holder. With the lamp free from the unit, carefully place it aside and remove the other lamp.
4. Dispose of the old lamps in the same way as ordinary fluorescent tubes. Note that old lamps should be disposed of at a household waste management depot or transfer station; contact your local recycling and waste management authority for proper disposal procedures in your area.

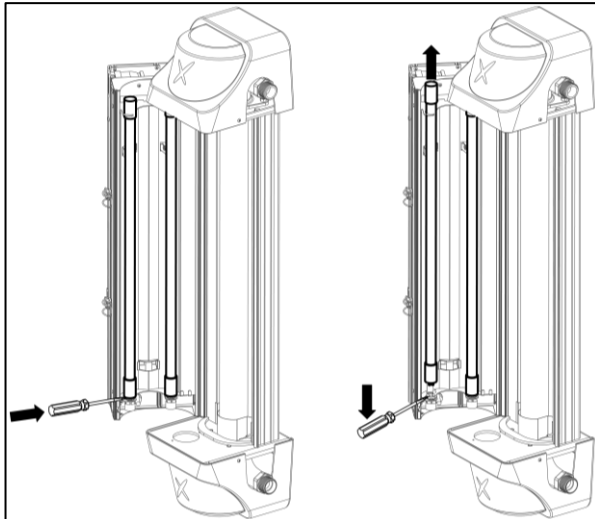

Figure 7-6

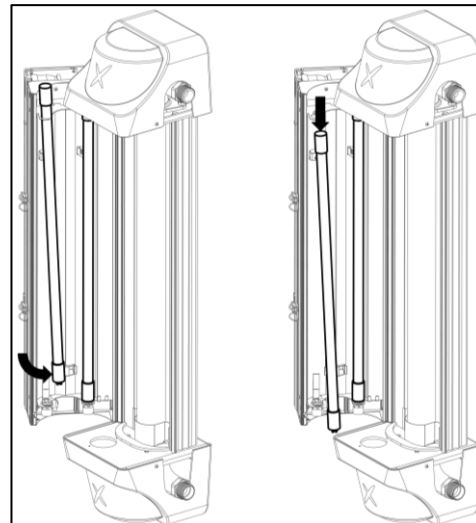

Figure 7-7

5. Install the new lamps into the unit one at a time, being careful not to touch the bulb. Insert the top end of the lamp through the top lamp holder then swing lamp base in over the socket. For a LPHO lamp, rotate it until the “Stop Sign” symbol printed on the top ceramic is towards the left. See Figure 7.5. For an amalgam lamp, rotate it until the wires running down the lamp are facing the back of the unit – a check mark has been added to the top ceramic on same side as the wires. The proper orientation of the LPHO and amalgam lamp has the lamp wires opposite the UV sensors.

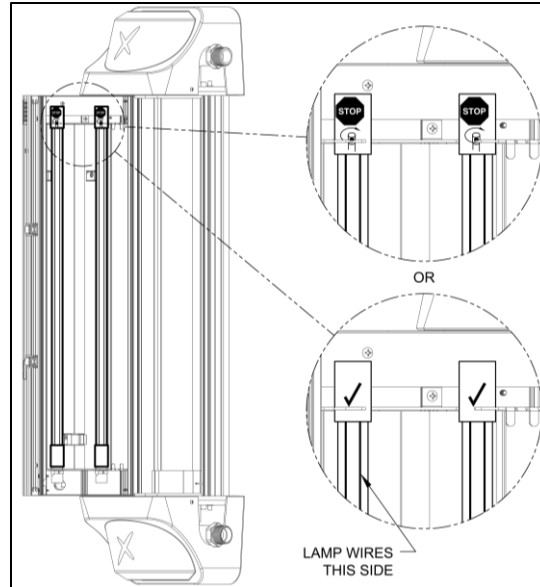

Figure 7-8

6. After the lamp has been rotated correctly, allow the 4 pins of the lamp to engage into the socket, push firmly down on the top of the lamp while holding socket. Do not twist the lamps when they are inserted. Observe the base of the lamp to confirm the pins are fully seated into the socket. Repeat for other lamp.
7. Close the UV Chamber and secure door.
8. Record the date of the lamp replacement in your Service Record Sheet.
9. Plug in the unit. The lamp lifetime counter can be reset in the Settings menu, item 2.5 (375 days for LPHO lamps, 500 days for amalgam lamps). **New LPHO lamps may take from a few moments to several hours to reach full power. Continue to operate the unit until the lamps reach full power.** The UV intensity value can be observed to confirm output levels. It is recommended for new LPHO lamps to be operated initially 3-4 hours as a burn-in to achieve lamp stability.

Draining the Unit

Draining is not normally required for routine operation or lamp replacement, but it is necessary to disassemble the system, to protect against freezing, or to remove poor-quality water.

Tools Needed: Pipe wrench

1. Shut off the water supply and relieve the pressure.
2. Shutdown and unplug the unit.
3. Place a bucket under the unit to collect the water.
4. Open a tap downstream of the unit to vent.
5. Open the optional drain valve, if installed, and disconnect the flexible hose or piping at the bottom port to allow the system to drain for a few minutes. Note that the water will not flow backwards through the optional automatic valve.
6. When draining is complete, close drain valve or reconnect flexible hose or pipe connections.
7. Close any taps that were previously opened.

Cleaning the Unit

Lync UV-H has an automatic quartz sleeve cleaning device within the systems to virtually eliminate the disassembly and cleaning of the quartz sleeve - the quartz sleeve will remain clear and transparent as glass. If a component of the cleaning device fails, such as the wiper motor, or in extreme water cases with unique water chemistry, the quartz sleeve may become fouled and require manual cleaning. In this situation the Dose Alarm will arise and alert you to the unsatisfactory conditions. Follow the steps below to inspect the quartz sleeve and disassemble the unit for cleaning.

Determining the Need for Cleaning

1. Shutdown and unplug the unit.
2. Open the UV chamber as described in Accessing UV Chamber section.
3. Examine the quartz sleeve both inside and out – See Figure 7.2. If it is clean, no disassembly is required and the unit can be closed. Restart the unit by plugging it in.
4. If the quartz sleeve is dirty on the outside, clean with a clean lint-free cloth and rubbing alcohol.

In-place Cleaning

This procedure will clean the quartz sleeve without its removal from the unit. This is a quick and easy procedure that works well in most cases.

Tools Needed: slotted screwdriver; Phillips screwdriver; pipe wrench.

1. Fill a bucket or container with 1 gallon (4 liters) of clean water - this will be required later to clean the quartz sleeve. A squeeze bottle is useful for applying water or cleaning solution to the inside of the quartz sleeve.
2. Shutdown and unplug the unit.
3. Shut off the water supply and relieve the pressure.
4. Open the UV Chamber as described in Accessing UV Chamber section.
5. Place another bucket under the unit and drain the unit until there is about 1" (3cm) of water left in the quartz sleeve (see Draining the Unit section).
6. Disconnect the fitting at the top outlet port of the UV unit. If the stainless flexible hose was installed, disconnect the hose opposite from the UV unit then bend the open end upwards – this will make the next step easier.
7. Add about 2 oz. (60cc) of cleaning solution to the top hose/manifold. The cleaning solution can be a citric acid, vinegar or other non-hazardous solutions. Any solution used should be thoroughly rinsed out afterwards. Fill the rest of the quartz sleeve with water.
8. Let the cleaning solution remain in the quartz sleeve for at least 10-20 minutes.
9. Manually turning the wiper may greatly assist the cleaning process. To do this, remove the top plastic cover then remove the motor and turn the wiper shaft with a slotted screwdriver (counterclockwise while looking at the shaft). If the optional wiper positioner switch is installed, leave the trigger cam in place.
10. Drain the unit and inspect the quartz sleeve. If clean, flush the unit with clean water. If fouling remains, repeat procedure or proceed to disassembling the unit.
11. Once the unit is clean, reassemble the system including the motor, plastic cover, top port connection(s) and UV chamber door.
12. Slowly open the water supply and check for leaks.
13. Restart the unit by plugging it in.

Disassembling the Unit

NOTE: This procedure is not recommended for untrained users - please contact your certified water specialist to assist should disassembly be required.

Tools Needed:

- Slotted screwdriver
- Philips screwdriver
- Pipe wrench
- 7/16" (11mm) wrench or nut driver

1. Bottle clean brush with long handle Fill a bucket with 1 gallon (4L) of clean water, required later to clean the quartz sleeve. A squeeze bottle is useful for applying water or cleaning solution to the inside of the sleeve.
2. Shutdown and unplug the unit.
3. Shut off the water supply and relieve the pressure.
4. Place another bucket under the unit and drain the unit completely (see Draining the Unit section). Note that piping connections to the inlet and outlet ports will have to be removed in order to disassemble the unit's stainless manifolds. Perform these disconnections now.
5. Open the UV Chamber as described in Accessing UV Chamber section. It may be necessary to have the UV chamber door held open for this procedure.
6. Remove top plastic cover.
7. Disconnect wires to wiper motor, purge valve, and water temperature sensor (thermistor).
8. Remove the wiper motor by removing the two screws holding it to the plate.
9. Remove the motor mounting plate from the top manifold by removing the two screws and nuts. Removing this plate will allow top manifold to come free from the wire bundle.

CAUTION! Do not damage sealing surfaces of manifolds or wiper shaft adapter - handle these parts with care to prevent water leaks. The wiper assembly must also be handled with care to prevent damage to cleaning edges. The wiper blades are sharp, handle them with care.

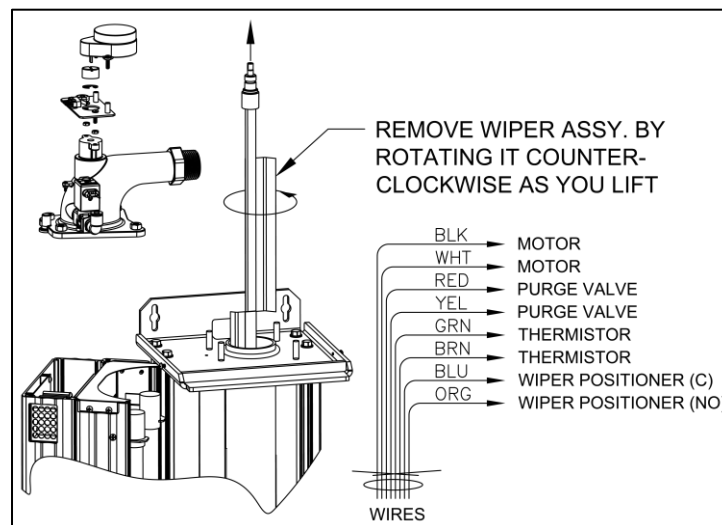

Figure 7-9

10. Remove the retaining ring (E-ring) holding the wiper shaft.
11. Use the 7/16" (11mm) wrench or nut driver to remove the four nuts of the top manifold in an alternating pattern (top left, bottom right, bottom left, then top right). The bottom manifold does not require removal to clean the quartz sleeve, so leave it in place. This will support the quartz sleeve during cleaning and simplify the overall process.
12. Press down on the wiper shaft and remove the top manifold (Figure 7.6) by lifting it straight up to disengage the wiper shaft. The shaft adapter should remain on the top of the wiper shaft. Note the orientation of the slot to the wiper blades – the slot is aligned to the wiper blades.
13. Remove the wiper assembly by carefully lifting it up and out of the quartz sleeve. Rotating it counter-clockwise as you lift will help. Prevent the shaft adapter from falling off the wiper assembly. Note that the shaft adapter sits on the top end of the wiper shaft - the top end of the shaft has a hole, the bottom end of the shaft does not.

Cleaning/Removing the Quartz Sleeve

1. Use a bottle cleaning brush with a long handle to scrub the inside of the quartz sleeve. Scrub and flush it with water repeatedly to clean the quartz sleeve. Use a squeeze bottle to apply water or solution to the quartz sleeve to keep the area tidy. Note: Keep the rest of the unit free from moisture. Examine the quartz sleeve.
2. If the quartz sleeve is still dirty, use a scale remover such as CLR or Lime Away and apply it to the inside of the quartz sleeve. Citric acid, available at a drug store, can also be used. Always flush with clean water afterwards.
3. Once the quartz sleeve is clean, reassemble the unit (see Figure 7.11). Replace any seals that appear to have been damaged.
4. If the quartz sleeve is still not clean, it requires replacement. This is done by removing the bottom manifold (see Figure 7.10). Replacing a quartz sleeve is easier when the unit is placed on a horizontal surface – removing the unit from the wall to work on a bench is recommended, especially for the UV-H 1000P models.

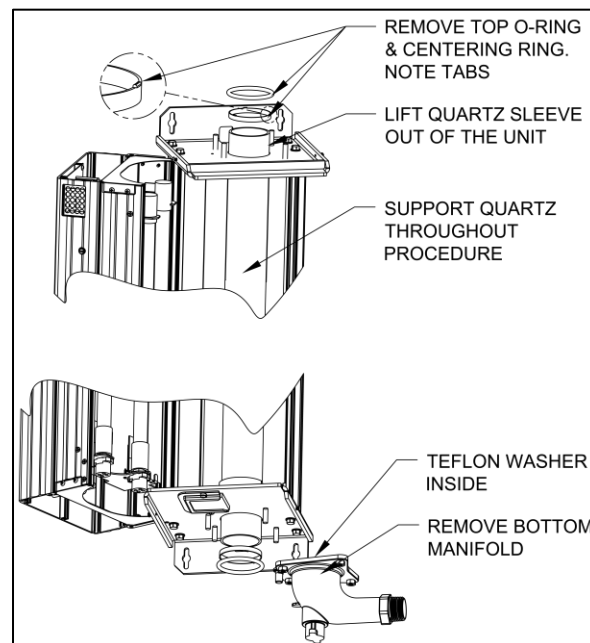

Figure 7-10

5. Remove the bottom plastic cover and then the bottom manifold by undoing the four nuts in an alternating pattern (top left, bottom right, bottom left, then top right). Do not allow the Teflon washer at the lower cavity of the bottom manifold to fall out – the wiper shaft sits on this washer. Support the quartz sleeve as you remove this item.
6. Remove the quartz sleeve by removing the top and bottom O rings and then the quartz centering rings. Lift the quartz sleeve out of the unit.
7. Install the new quartz sleeve into the unit and center it vertically. **Be careful not to chip the ends.** Support the quartz sleeve for the next two actions.
8. Install the quartz centering rings (small tabs face outwards) and then the top and bottom O rings, keeping the quartz sleeve centered vertically in the unit.
9. Replace the bottom manifold (see Fig. 7.10) by installing the four nuts in an alternating pattern (top left, bottom right, bottom left, then top right). Check again for Teflon washer.

Reassembling the Unit

1. Replace the wiper assembly carefully in the quartz sleeve -wetting the inside of the quartz sleeve with water will also make the task easier. Turn the wiper assembly counter-clockwise (looking from the top) as it is being inserted into the quartz sleeve – this will make the task easier and align the wiper blades properly. Ensure the bottom of the wiper is correctly seated into bottom manifold.

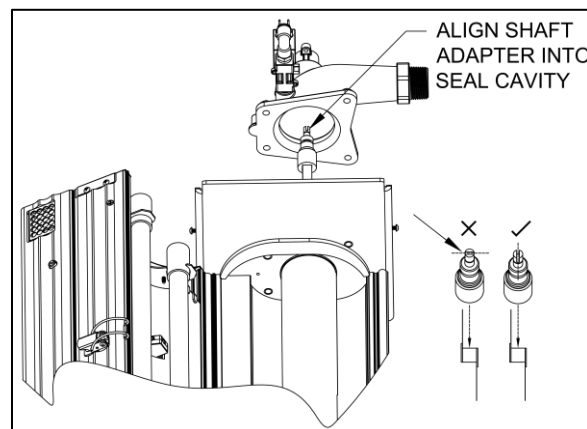

Figure 7-11

2. Ensure quartz O-ring seal is in place around quartz sleeve and then replace the top manifold by aligning the shaft adapter into the seal cavity of the top manifold (see Figure 7.11).
3. Tighten the nuts in an alternating pattern. Once top manifold is secure, replace the retaining ring on the wiper shaft. Rotate the wiper assembly CCW so the top wiper blade faces the back of the unit.
4. Reconnect both top and bottom piping connections. Close the UV Chamber door.
5. Close any taps and slowly open the water supply. Inspect for leaks. Repair any leaks if necessary before plugging in the unit.
6. Reinstall the motor mounting plate by using the trigger cam to center the plate (center hole to be concentric with wiper shaft). With the wiper blade opposite the UV sensor facing the back, the trigger cam should have the dimple in the 10 o'clock position. Install the wiper motor, then reconnect all the wires.
7. Reinstall the top and bottom plastic covers.
8. Plug in the unit. Check operation of wiper motor, purge valve and water temperature switch.
9. Make an entry in the service record to establish a cleaning schedule

Replacement Parts

Use only genuine parts from Lync when servicing your UV-H disinfection system. Failure to use genuine replacement parts will void the factory warranty, and any laboratory validation and/or certification for water safety and system operating performance. Figures 7.12-13 show a list of original factory parts.

Replacement parts and service are available from Lync representatives.

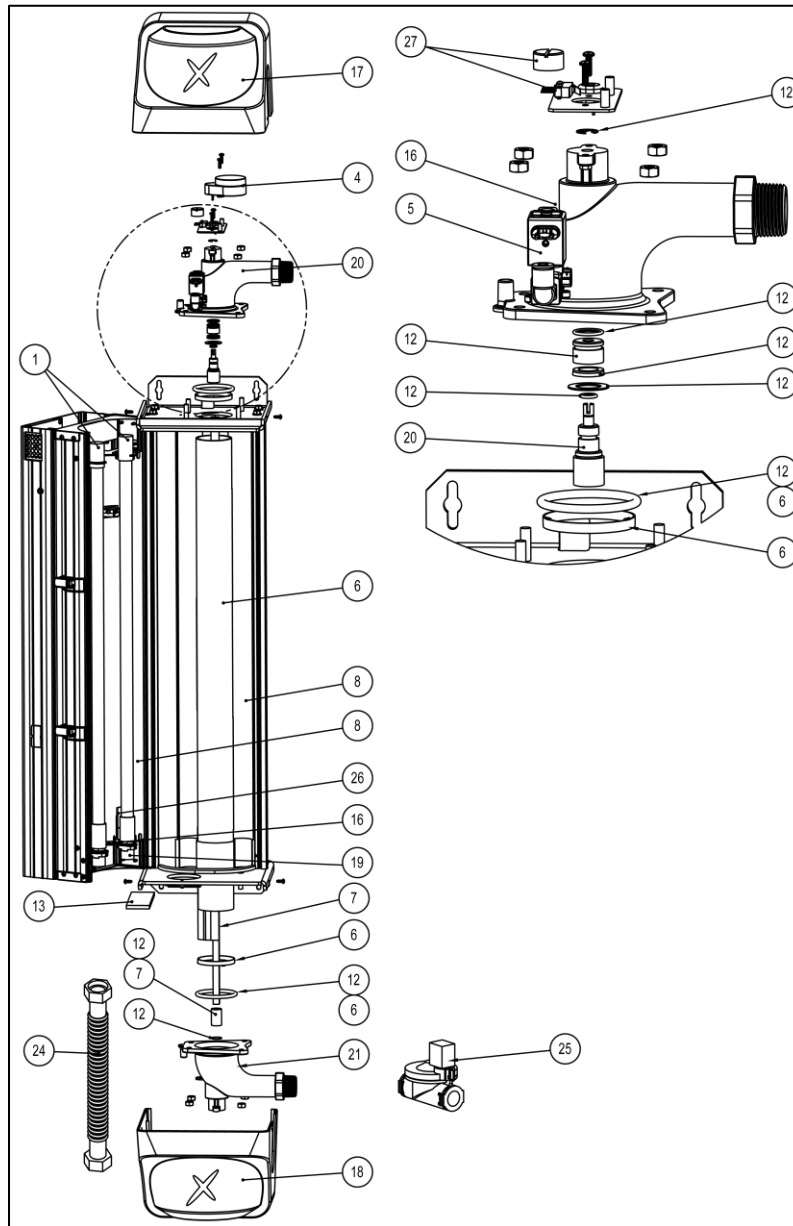

Figure 7-12

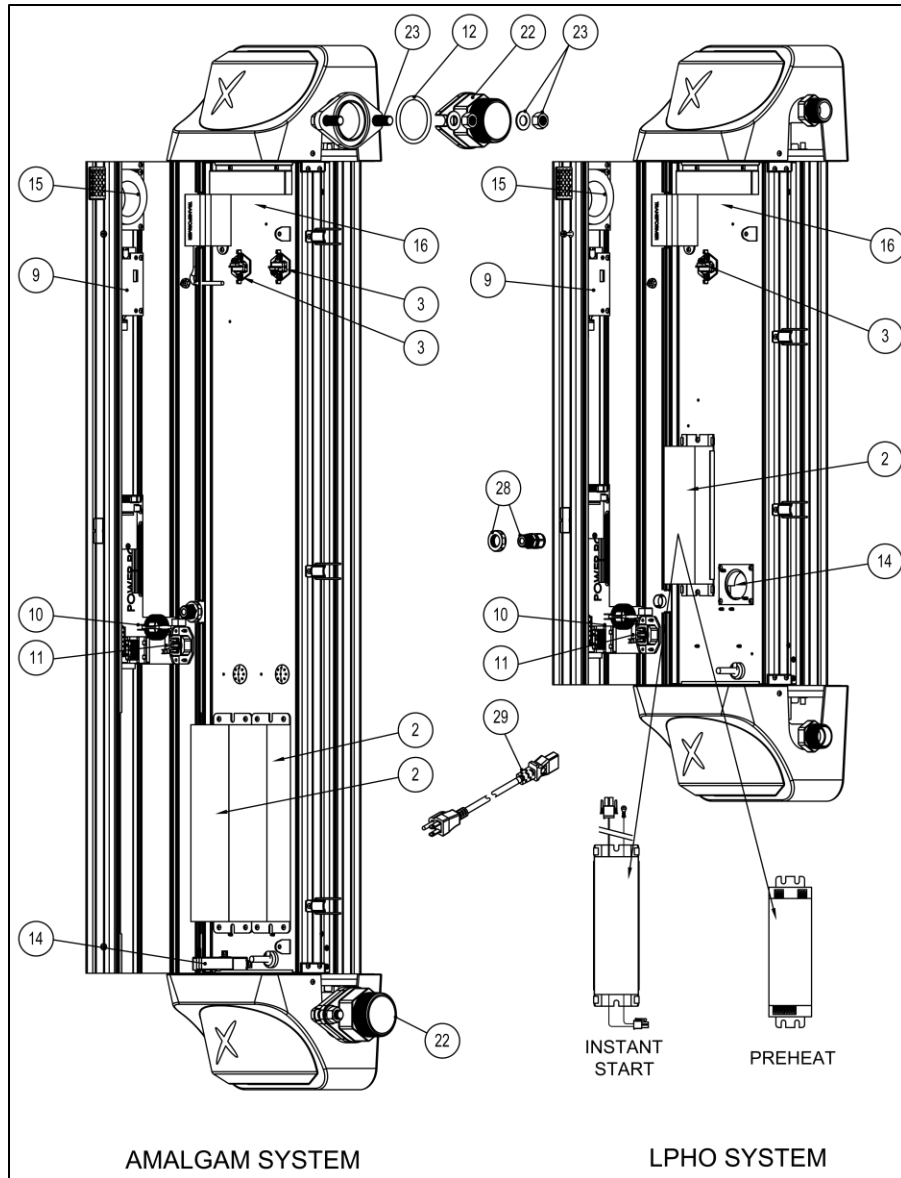

Figure 7-13

UV-H Spare Parts List

Item No.	Part Name	Model	
		UV-H 1000P (WQAS-070-X and WQAS-100-X)	UV-H 750P (WQAS-040-X)
1	UV Lamps (Shipped in pairs)	GC19	C300065 (single lamp p/n is C300064)
2	Electronic Ballast	GD37 (2 per unit)	GD40 (for 120V instant start systems) (1 per unit) GD41 (for preheat & 230V systems) (1 per unit)
3	UV Sensor Kit	GD1 (some units have 2 - see Product Spec. Table)	
4	Wiper Motor Kit	R400005	
5	Purge Valve Kit	H400000	
6	Quartz Sleeve Replacement Kit (includes 2 O rings)	GDQ-XL	GDQ-L
7	Wiper Assembly Kit	GDW-XL	GDW-L
8	Reflector Kit (shipped & sold in pairs)	GDR-XL	GDR-L
9	Circuit Board - LCD	Contact Lync customer support	
10	Circuit Board – Power	GD3 (for 120V systems) GD3-230 (for 230V systems)	
11	Fuse Pack (5 pcs)	GD4 (for 120Vac systems, fuse is 6A, 250V 3AG) GD50-230 (for 230Vac systems, fuse is 3.15A, 250V 5x20mm IEC)	
12	Seal Kit (complete)	GD5 (2" Port)	GD6 (1" port)
13	Air Filter	GD7	
14	UV Chamber Blower Kit	GD8	
15	Circuit Board Blower Kit	GD9	
16	Temperature Sensor (Thermistor) Kit	GD10 (3 per unit)	
17	Top Plastic Cap	GD11	
18	Bottom Plastic Cap	GD12	
19	Lamp Socket Wire Harness	GD42 (2 per unit)	GD43 (for 120V instant start systems) (1 per unit) GD44 (for preheat & 230V systems) (2 per unit)
20	Top SS Manifold/ Thermistor/Purge Valve Kit	GD13 (2 inch)	GD14 (1 inch)
21	Bottom SS Manifold	GD15 (2 inch)	GD16 (1 inch)
22	2" NPT Adapter (1 pc.)	GC25	
23	Fastener Kit for 2" Adapter (2 per unit)	GD22	
24	Optional Flexible SS Hose	GD17 (2" hose)	R400007 (1" hose)
25	Optional Solenoid shut-off Valve – Nylon		550229 (1" ports)
	Optional Solenoid shut-off Valve – Brass	550231	550195 (1" ports)
26	Heaters for LPHO Lamps		GD18
27	Wiper Position Switch Kit	GD19	
28	Optional Strain Relief Kit	GD21	

29	Power Cord	150013 - for 120V (North America)	
-	Purge Valve Relocation Kit	GE3 (equivalent to H500001)	
-	10gpm Flow R. Kit		GD24
-	13.2gpm Flow R. Kit		GD25
-	15gpm Flow R. Kit		GD26
-	18.5gpm Flow R. Kit		GD27
-	20gpm Flow R. Kit		GD28
-	25gpm Flow R. Kit		GD29
-	26.4gpm Flow R. Kit		GD30

