

Installation, Operation and Maintenance Manual

BOLT MINI

Electric Water Heater



Disclaimer

The information contained in this manual is subject to change without notice from Watts Heating and Hot Water Solutions LLC dba Lync by Watts ("Lync"). Lync by Watts makes no warranty of any kind with respect to this material, including, but not limited to, implied warranties of merchantability and fitness for a particular application. Some states do not allow the exclusion or limitation of incidental or consequential damages, so the above limitation may not apply. Lync by Watts is not liable for errors appearing in this manual, nor for incidental or consequential damages occurring in connection with the furnishing, performance, or use of these materials.

Engineered Solutions

Watts Heating and Hot Water Solutions LLC dba Lync by Watts
425 W Everman Pkway, St. 101 • Fort Worth, TX 76134

USA: T: (817) 335-9531

Technical Support • (800) 433-5654 (ext. 3) • Mon-Fri, 8 am - 5 pm CST

© 2026 LYNC

TABLE OF CONTENTS

- 1. SAFETY CONSIDERATIONS3**
- 2. PRODUCT DESCRIPTION5**
- 3. WATER HEATER INSTALLATION6**
 - 3.1. Checking Equipment Before You Install.....6
 - 3.2. Codes6
 - 3.3. Water Quality Requirements.....6
 - 3.4. Electrical Requirements7
 - 3.5. Location7
 - 3.6. Installation.....8
 - 3.7. Service Clearances8
 - 3.8. Clearances to Combustible Surfaces9
- 4. OPERATING AND SAFETY CONTROLS 10**
 - 4.1. Temperature and Pressure Relief Valve 10
 - 4.2. Electronic Low Water Cut-Off 10
 - 4.3. Operating Temperature Control 10
 - 4.4. High Water Temperature Limit..... 10
- 5. OPERATING TEMPERATURE CONTROL FEATURES..... 12**
 - 5.1. Modes of Operation 12
 - 5.2. Control Settings..... 12
 - 5.3. Control Diagnostics and Status Icons..... 15
 - 5.4. Control Communications 16
- 6. START-UP PROCEDURES AND OPERATION..... 17**
- 7. ELEMENT CONTINUITY CHECKS 18**
- 8. MAINTENANCE..... 19**
 - 8.1. Flushing 19
 - 8.2. Sediment / Lime Scale 19
 - 8.3. Temperature and Pressure Relief Valve 20
 - 8.4. Low Water Cutoff..... 20
 - 8.5. Electrical Connections..... 20
 - 8.6. Electric Element Care 20
- 9. TROUBLESHOOTING..... 20**
- 10. WIRING DIAGRAMS..... 23**
- 11. REPLACEMENT PARTS..... 25**

1. SAFETY CONSIDERATIONS

⚠ WARNING!

Improper installation, adjustment, alteration, service or maintenance can cause property damage, significant personal injury, exposure to hazardous materials, or death.

FOR YOUR SAFETY:

Do not store or use gasoline or other flammable liquids near this unit, or any other appliance.

WHAT TO DO IF YOU SMELL GAS

- Do not try to light any appliance.
- Do not touch any electric switch; do not use any phone in your building.
- Immediately call your gas supplier from a location away from your building and the smell of gas. Follow the gas supplier's instructions.
- If you cannot reach your gas supplier, call the fire department.

⚠ WARNING!

Installation and service must be performed by a qualified installer, service agency or qualified electrical contractor, who must read and follow the supplied instructions before installing, servicing or removing this unit. Refer to the information contained in this manual.

You must consult local building and plumbing codes prior to installation. If the information in this manual is not consistent with local codes, the local codes should be followed. Inquire with governing authorities for additional local requirements.

⚠ WARNING!

Do not use this unit if any part has been under water. Immediately call a qualified service technician to inspect unit and replace any parts or items affecting safe operation that have been under water.

⚠ WARNING!

In an emergency, disconnect all electrical power to the unit from a location safely away from the emergency. Failure to follow these instructions can cause property damage, personal injury, exposure to hazardous materials or death.

⚠ WARNING!

It takes only 5 seconds of skin contact with 140°F water to cause a second degree burn. You must protect against high water temperatures in all lavatories, tubs, showers, and other points of hot water contact.

Accidental scalding from hot water is a greater risk in facilities for the young, old, or otherwise impaired.

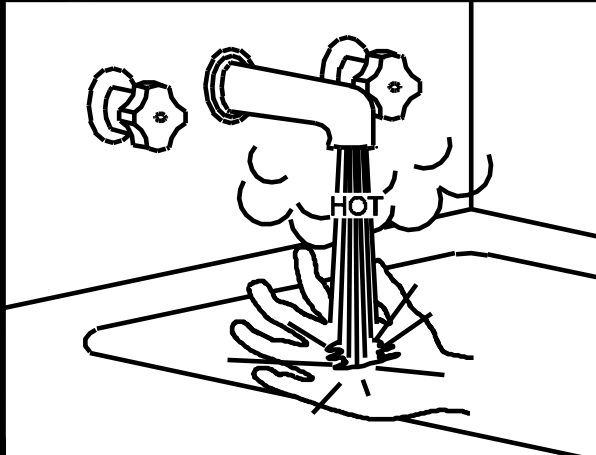
 DANGER	
	<ul style="list-style-type: none">● Water temperature over 125°F can cause severe burns instantly or death from scalds.● Children, disabled and elderly are at highest risk of being scalded.● See instruction manual before setting temperature at water heater.● Feel water before bathing or showering.● If this appliance is used to produce water that could scald if too hot, such as domestic hot water use, adjust the outlet control (limit) or use temperature limiting valves to obtain a maximum water temperature of 120°F.

IMPORTANT

- Thermostatically controlled mixing valves must be used in the design of the potable hot water system.
- Potable hot water should be tempered to no more than 110°F for bathing or other personal uses.
- Thermostatically controlled mixing valves set at 120°F or less to keep the delivered water temperature below scalding temperatures.

2. PRODUCT DESCRIPTION

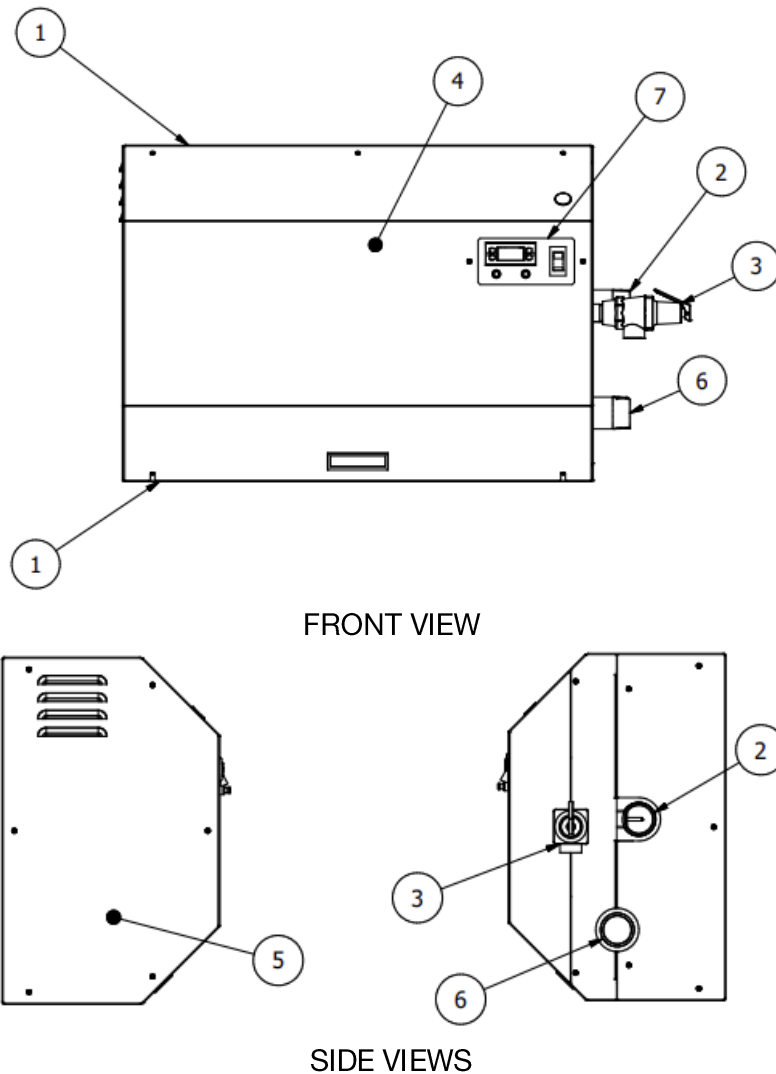

Figure 2-1: Bolt Mini Electric Water Heater

1. Electrical Entry
2. 1 ½" NPT Hot Outlet
3. T&P Relief Valve
4. Control Enclosure
5. Heating Element Access Panel
6. 1 ½" NPT Cold Inlet
7. Control Panel

NOTE: The Lync Bolt Mini may be used as a primary heating source, back-up or booster to a heat pump or other heater, or as a recirculation heater for a heat pump system.

3. WATER HEATER INSTALLATION

3.1. Checking Equipment Before You Install

Inspect the unit completely upon receipt from the freight carrier before signing the bill of lading. Inspect the unit and all accompanying parts for signs of impact or mishandling. Verify the total number of pieces shown on packing slips with those received. Contact the freight carrier immediately if any damage or shortage is detected.

3.2. Codes

The equipment must be installed in accordance with the local installation regulations. Authorities having jurisdiction must be consulted before installation is made. In the absence of such requirements, the installation shall be in accordance with the instructions in this manual, unit markings, and supplemental instructions. Installation must also be in compliance with the latest edition of the National Electrical Code, NFPA-70. In Canada, the equipment must be installed in accordance with the latest edition of the Canadian Electrical Code, C22.1 and any applicable provincial regulations. All ASME-rated units conform to the current edition of the ASME Boiler and Pressure Vessel Code, Section IV, Part HLW.

3.3. Water Quality Requirements

Water quality must follow the EPA's national primary drinking water regulation limits. Lync suggests that water flowing through the water heater meets the following water conditions.

Total hardness	1.2 to 3.5 grains/gallon
pH	7.5 to 8.5
Electrical conductivity	1 to 600 QS/cm
Hydrogen carbonate (HCO_3^-)	70 to 300 ppm
Sulphates (SO_4^{2-})	< 50 ppm
Hydrogen carbonate / Sulphates ($\text{HCO}_3^-/\text{SO}_4^{2-}$)	> 1
Chlorides (Cl^-)	< 50 ppm
Nitrates (NO_3^-)	< 50 ppm
Sulphuric acid (H_2S)	< 0.05 ppm
Ammonia (NH_3)	< 0.05 ppm
Sulphites (SO_3), free chlorine (Cl_2)	< 1 ppm
Carbon dioxide (CO_2)	< 5 ppm
Metal cations	< 0.2 ppm
Manganese ions (Mn^{++})	< 0.1 ppm
Iron ions (Fe^{2+} , Fe^{3+})	< 0.2 ppm
Iron + Manganese	< 0.5 ppm
Phosphates (PO_4^{3-})	< 2 ppm
Oxygen	< 0.1 ppm

It may be necessary to de-scale the pressure vessel periodically, depending on water conditions. The frequency of cleaning can be determined locally based on the performance of the heater and calcium hardness levels shown in the table below.

Calcium Hardness Level	<3.5 grains/gal (<60 mg/L)	3.5-7.0 grains/gal (60 – 120 gm/L)	7.0-10.5 grains/gal (120 – 180 mg/L)	>10.5 grains/gal (>180 mg/L)
Suggested Cleaning Frequency	Biennially	Annually	Semi-Annually	Monthly

Hard Water is generally considered to be any condition >3.5 grains/gallon (>60 mg/L). To extend the life of equipment, guarantee the highest performance, and reduce the required cleaning frequency, Lync recommends installing a scale mitigation system such as Lync AquaSolve anti-scale systems or a traditional salt-based softening technology.

Ultrapure water can also cause corrosion in a domestic water system as it does not have dissolved solids, which prevents water from stealing ions from metallic system piping and components. Ultrapure water is created by running natural water through a filtration process, such as reverse osmosis, where all minerals and contaminants are removed and creates an extremely low electrolytic conductivity.

3.4. Electrical Requirements

IMPORTANT

Check all wiring connections to ensure tightness prior to use.

Only use copper wire that is the correct size, as indicated. Damage resulting from use of aluminum wiring is excluded from coverage under the warranty for this unit.

1. Check the rating plate on the front of the unit for correct voltage, phase, and amperage. Refer to Section 7: Element Continuity Checks for all electrical offerings by heater model and input rating. Refer to the wiring diagrams in Section 10 for the control components mounted inside the heater.
2. Use proper wire size and circuit protection as required by either the National Electrical Code, NFPA-70, Canadian Electrical Code, C22.1, and any additional local codes.
3. Use proper wire size for ground connection. Attach to the ground connection marked "GR".
4. Connect supply feeders to the contactor inside the enclosure on the heater.

3.5. Location

1. Install the unit indoors only, in a clean and dry area, and as near to electrical power as is practical. It should be located as close as possible to where the most hot water is used.
2. Install the unit on or over a pitched floor near a suitable drain, or as far away as possible from areas of the building subject to water damage, in case the water heater or a water connection leaks. The drain must be sufficient to withstand water in excess of 210°F .
3. The water heater should be secured to the wall-mounting surface by putting at least four screws through the mounting holes. These mounting holes are accessible through the interior of the water heater and located along the backside wall of the enclosure. Ensure that the surface is solid and secure, and that the water heater is level prior to securing it to the mounting surface. Attach directly to metal or wood framing.
4. Floor mounting tools are optionally provided with the unit. Code requirements vary by geographical location, and additional strapping or braces may be required. Please refer to your local codes for requirements for additional equipment.

⚠ WARNING!

As with any electrical product, care should be taken to guard against the potential risk of fire, electric shock, and injury to persons.

3.6. Installation

⚠ WARNING!

Use industry standard safe rigging methods when lifting or moving. Failure to follow these instructions could result in property damage, serious injury or death. One common method uses straps and spreader bars to lift unit from the water heater base skid assembly.

IMPORTANT

Use only non-ferrous nipples for connections to tank.

1. Check data decal on the heater. Be sure the electrical supply is adequate for installation.
2. Carefully remove all shipping supports and bracing.
3. Install shut-off valves and unions on inlet and outlet piping for servicing. Use caution when threading pipe nipples into tank connections to prevent cross threading or over-tightening. Always use a back-up wrench on tank nipples when tightening unions, valves, etc. It is recommended to install flush ports near the inlet and outlet plumbing connections of the water heater for periodically flushing the buildup of sediment out of the heating chamber.
4. Insulate hot water and return circulation lines. Additionally, if the area is subject to freezing, insulate all water piping and take the necessary steps to keep the unit, and all water containing pipes and components, from freezing. Do not use plumbing connected to the unit as a ground for welding or any other purpose.
5. The water heater is equipped with a temperature and pressure relief valve rated for the input. Pipe the relief valve discharge to a suitable open drain. The drainpipe may not be smaller than the relief valve opening and must be secured to prevent it from lifting out of the drain under discharge pressure. Do not install valves or restrictions in the discharge line.
6. Pipe the flush port to a suitable open drain.
7. Inspect, maintain and service the temperature and pressure relief valve as provided on the instructions attached to the valve.
8. A thermal expansion valve (or diaphragm-type expansion tank) should be installed in the cold water line between the water heater and any check valve.

3.7. Service Clearances

Allow sufficient clearance space on the top, bottom, front and sides for service and inspection. The recommended clearances are 12" in front and 12" on the left side for servicing the heater, and 8" on the right side past the enclosure for the relief valve and water connections. Optional equipment may increase the clearance requirements. Allow sufficient space for installing and servicing connections such as water, electrical, pump and other auxiliary equipment.

It is required to consult the local building and plumbing codes prior to installation. If the information in this manual is not consistent with more stringent local building or plumbing codes, the local codes should be followed. Inquire with governing authorities for additional local requirements.

3.8. Clearances to Combustible Surfaces

The minimum installation clearances to combustible material are 2” on the top, front, and bottom faces, as well as 12” on the left side and 8” on the right side when facing the heater control panel.

⚠ WARNING!

Turn off all electrical service to the appliance when accessing the limit or other controls located inside the enclosure. Close and fasten the enclosure front panel before restoring electrical service to the appliance. The enclosure contains high-voltage wiring and terminals. If the electrical service is not turned off and these terminals are touched, a dangerous shock causing property damage, personal injury, or death could occur.

4. OPERATING AND SAFETY CONTROLS

4.1. Product Enclosure Labels and Warnings

Several information labels and warnings are displayed on the outer enclosure of the heater.

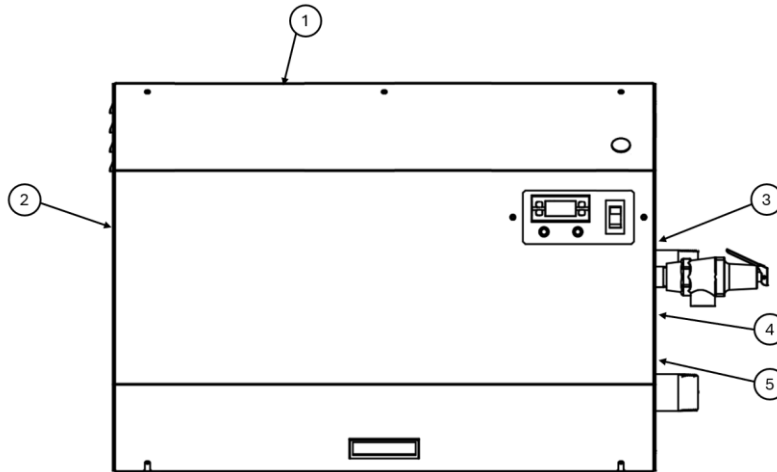

Figure 4-1: Bolt Mini Label and Warning Locations

1. Product Label with Electrical Warnings and Clearances
2. Electrical Shock and High Voltage Warnings
3. Hot Outlet Label and Pipe Fitting Material Warnings
4. Temperature and Pressure Relief Valve Label
5. Cold Inlet Label

4.2. Temperature and Pressure Relief Valve

The temperature and pressure relief valve is a safety device rated for the heating input. Pipe the relief valve discharge within 6-12" of a suitable open drain, ensuring enough height for visual identification of any discharge. The drainpipe may not be smaller than the relief valve opening and must be secured to prevent it from lifting out of the drain under discharge pressure. Do not install valves or restrictions in the discharge line.

4.3. Electronic Low Water Cut-Off

The electronic low water cut-off consists of a probe in the tank that acts as a switch, closed when submerged in water and open when the water level is below the probe, preventing heating elements from energizing. The probe should be kept free of scale buildup to ensure operation.

4.4. Operating Temperature Control

The front control panel houses an adjustable digital operating control, which is factory pre-set at approximately 140°F. For more information, see the Operating Temperature Control Features section in this manual.

4.5. High Water Temperature Limit

The High Water Temperature Limit is an electro-mechanical, manual reset safety device. This limit is attached to the surface of the pressure vessel, and has a trip setting of 190°F. In the event the internal water temperature exceeds this setting, this device will open the safety circuit and stop heater operation. Once the cause of this condition has been corrected, this device must be manually reset before operating can continue. To do this:

- Disconnect main power to the water heater
- Remove the front cover
- Press the black button in the middle of the limit as shown below.
- The electrical connection on the limit may be energized with 120Vac if power is not disconnected

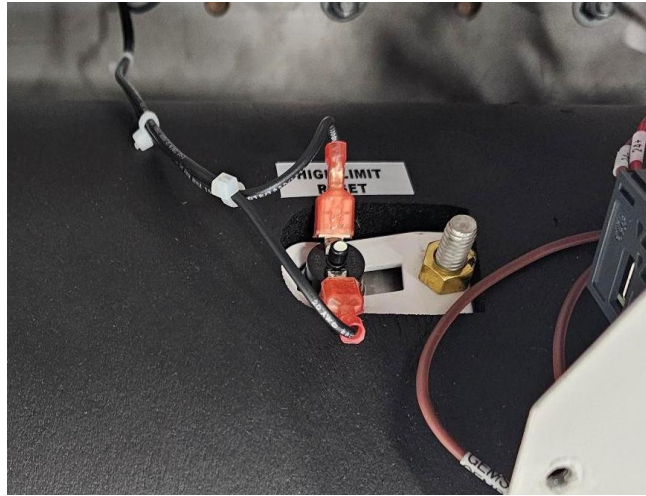

Figure 4-2: High Water Temperature Limit Reset

⚠ WARNING!

The electrical connection on the limit may be energized with 120VAC if power is not disconnected.

5. OPERATING TEMPERATURE CONTROL FEATURES

5.1. Modes of Operation

The Bolt Mini Electric Water Heater is capable of three modes of operation:

- Recirculation Water Heater:** In this mode, the recirculated water from a distributed hot water system such as an apartment building or a hospital loses heat as it moves through a building and requires reheat apart from the primary heating plant. This may be required when a primary heating plant consists of heat pumps which are designed for specific water temperature ranges. In this mode the water flow rates may be higher than other applications, but the water temperature rise, or ΔT may be relatively low.

Model	kW Rating	Maximum Flow Rate at Temperature Rise (gpm @ °F ΔT)								
		10°F	20°F	30°F	40°F	60°F	80°F	100°F	120°F	140°F
LLAR12	12	8.2	4.1	2.7	2.0	1.4	1.0	0.8	0.7	0.6
LLAR18	18	12.3	6.1	4.1	3.1	2.0	1.5	1.2	1.0	0.9
LLAR24	24	16.4	8.2	5.5	4.1	2.7	2.0	1.6	1.4	1.2
LLAR30	30	20.5	10.2	6.8	5.1	3.4	2.6	2.0	1.7	1.5
LLAR36	36	24.6	12.3	8.2	6.1	4.1	3.1	2.5	2.0	1.8
LLAR45	45	30.7	15.3	10.2	7.7	5.1	3.8	3.1	2.5	2.2
LLAR54	54	36.8	18.4	12.3	9.2	6.1	4.6	3.7	3.1	2.6

- Point of Use:** In this mode, the heated water may be used directly from a sink or dishwasher or anywhere a user could dispense heated water. It is also likely that this water was heated from ground water temperature to the desired hot water temperature. ***This heater is not designed to be used for applications where the user could be exposed directly to scalding water, such as a shower or bath.***
- Side Arm Heater.** In this mode, the heater can be paired with a storage tank and the water from the tank would be circulated through the heater and sent back to the tank. For this mode, the heater will regulate the water temperature based on an optional temperature sensor remotely located in the storage tank.

5.2. Control Settings

The Bolt Mini Operating Temperature Control has 5 menus:

Press the SET Button

- USER MENU (Commonly used settings)
- TEMP MENU (All of the temperature sensors can be viewed here)
- COM MENU (Setting to set up communication using MODbus)

Press the SET + ESC Button at the same time, then enter the Password

- FACTORY MENU (Do not make changes without factory guidance)
- PID MENU (Do not make changes without factory guidance)

The **USER** menu contains all the parameters that most users will need to adjust as well as a status screen. This menu is not password protected and can be accessed by pressing the **SET** button two times. The first screen on the display is **CntF**. This temperature is read-only and represents the temperature at the sensor, which is actively controlling the heater output. This can change depending on the mode of operation. Pressing the **UP** arrow once will move the screen to the **StAC** screen. This is a read only display of the setpoint which the heater is controlling to.

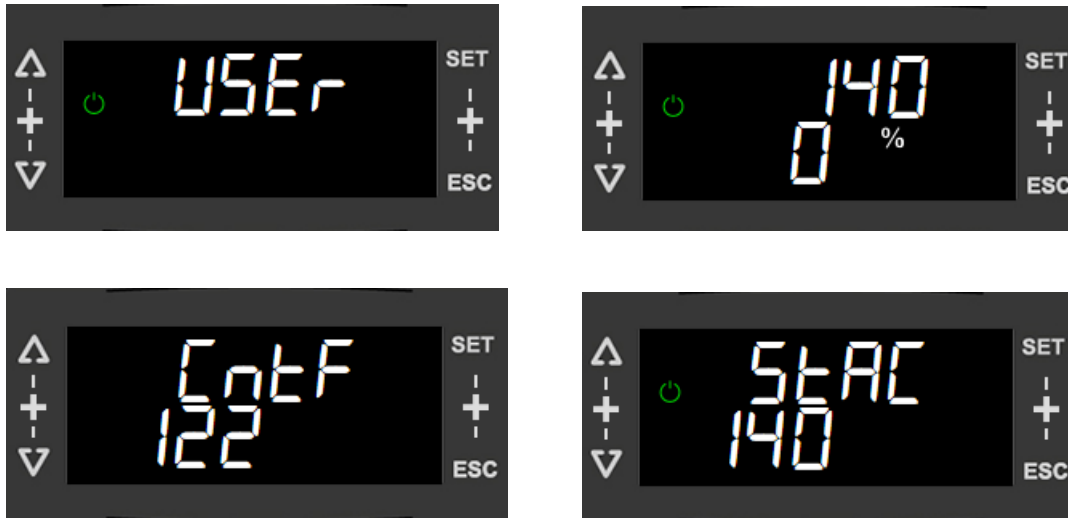

Pressing the **UP** arrow again will display the first parameter in the **USER** menu. The **SEt1** parameter is the primary controlling water temperature set point. The default setting is 140°F. To change this parameter, press the **SET** button and you will see the display change to image below. The green flashing circle indicates the parameter can be adjusted using the arrow buttons. Once the desired set point is adjusted, lock this change in by pressing the **SET** button again. Now you can move to the next screen by pressing the arrow buttons. This general procedure will be the same when adjusting any parameter. You may exit menus by pressing the **ESC** button multiple times until the desired menu or home screen is reached.

The next parameter is **SEt2**. This allows the user to take advantage of a secondary water temperature set point when needed. The default setting for this parameter is 120°F. To energize this set point shift, 24Vac must be applied to the terminals labeled **SP2**. See the section on wiring for more details.



The next parameter in the **USER** menu is **CrM**. When the heater is initially powered, the **Control Mode of Operation** is set to **Unit Off**. The default setting is off to allow the user to correctly set up operation for their system. Once the Control Mode is selected, and all safeties and interlocks are made, the heater will begin to operate. Press the **SET** button, select the mode, and press **SET** again to lock in selection.

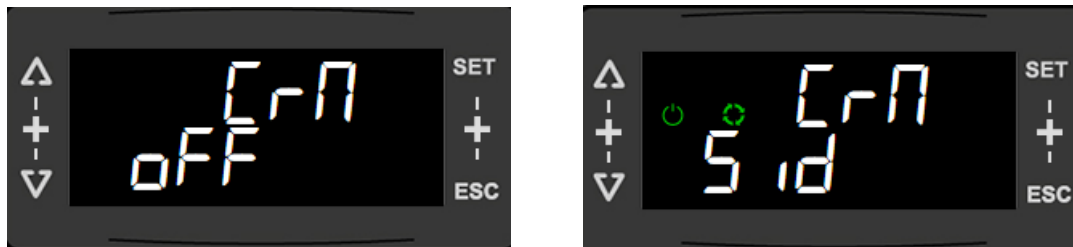

The **TEMP** menu locates all the temperature sensor values in one place. This menu is not password protected and can be accessed by pressing the **SET** button once to enter this menu level. Press the **UP** arrow once and the **SET** button once to enter this menu. This menu allows the user to see all the system temperatures in one location to understand both operation as well as identify defective sensors.



The **FACTory** menu contains both parameters as well as status screens. These parameters are password protected and should only be adjusted by factory trained personnel. To access this menu, press the **SET** and **ESC** button at the same time. The **Par** screen will appear. Press the **UP** arrow for the **PASS** entry to appear, then press **SET**. Enter the password and press **SET** again. Now use the arrow button to move to the **FACTory** menu.



The first parameter in this menu is **DiF I**, and the default setting is **-5°F**. This differential will be the absolute temperature value below the active set point at which the heating action will begin. The heating action will end when the water temperature exceeds the active set point.

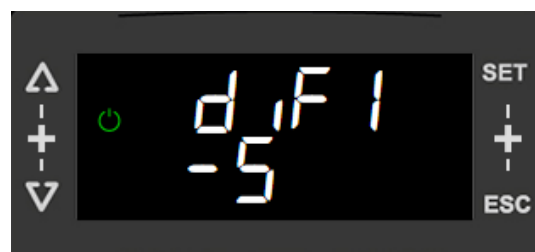

The next factory parameter is an activation switch for **Manual Override** output or **MA_n**. Press the **SET** button and use the arrow button to change to the on position and press **SET** to lock in this selection. Press the **UP** arrow again to move to the next parameter **MA_r** which will allow the user to set the heat output from 1 to 100%. Press **SET** to adjust and **SET** again to lock in this setting.

⚠ WARNING!

When using Manual Override, ensure that water is flowing through the unit to prevent overheating.



The last parameter in the **USER** menu is **rEv**. This displays the current software version.

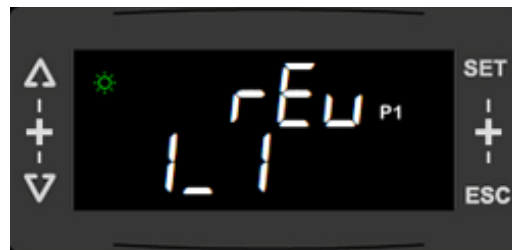

5.3. Control Diagnostics and Status Icons

The control screen will display multiple icons which indicate both general status and faults. The following home screen image illustrates three indications. The number on the top row is the temperature of the water at the heater outlet. Directly below this number is the percentage of heat output display as 0 to 100%. In this case the heater control is satisfied, and the heat output is 0%. The green icon to the left of the screen represents a flashing on power symbol. This icon indicates that the remote enable/disable input is disabled, and the heater will not operate. This function is activated by remotely powering the **R1** & **R2** terminals in the heater cabinet. Applying 24Vac to these terminals will disable operation.



The display illustrations below illustrate the following:

- The red flashing triangle indicates an alarm.
- The flashing number "1" indicates that the alarm is a low water condition.
- The flashing number "2" indicates that the alarm is a high temperature water condition.
- The flashing number "3" indicates that the alarm is an SSR fault.
- The flashing number "4" indicates that a sensor fault has occurred.
- The green sun icon indicates that the unit is actively heating water.
- The green leaf icon indicates that set point **SEt2** is the **Active Setpoint**.

- The “P3” icon indicates that the control mode is for **Side Arm** heating and the circulation pump is operating.
- The “P2” icon indicates that the control mode is for **Point of Use**.
- The “P1” icon indicates that the control mode is for **Recirculation**.
- The “P4” icon indicates that the **Manual Override** is activated.



5.4. Control Communications

This product is equipped with an RS485 communication port using the MODbus RTU protocol. This allows the user to communicate between a manager control system and the water heater (client).

The user can configure this port by accessing the **CoM** menu. Press the **SET** button and then the **DOWN** arrow once to locate. Press the **SET** arrow to enter this menu. The first parameter is **CF30**. This parameter allows the user to select a unique **Device Address** for this control. This address can be from 1 to 247.



The next parameter is **CF31**. This parameter will select the **Baud Rate** from 9600 to 115200. **CF32** is the Parity which can be Null, Even or Odd.



The last parameter is **CF33**, **Stop Bit** which can be 1 or 2.



The method of use for the RS485 is as follows:

- The terminals are identified as shown here. Use a shielded and "twisted pair" cable with two 0.5 mm² section conductors (AWG 20), plus braid (characteristic impedance 120 Ω) with PVC sleeve, nominal capacity between conductors 36 pF/m, nominal capacity between conductor and shielding 68 pF/m.
- Always follow regulations applicable to the routing and connection of cables. Separate data transmission circuits from power lines.
- RS-485 network up to 1200 m in length with a maximum of 32 devices can be connected directly to the controller. This length can be extended, and the number of devices for each channel increased using appropriate repeater modules.
- Attach the 120 Ω 1/4 W resistors between the "+" and "-" terminals of the interface and the last controller in each branch of the network.
- The table below shows the register address which can be utilized by a master control system. Do not attempt to write to address other than the one listed below

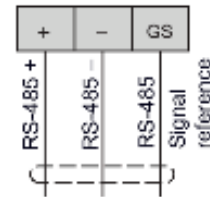

Register Name	Address	Register Format	Default Value	Unit	Minimum Setting	Maximum Setting	Read/Write Read Only
Setpoint 1	16384	16-bit Integer	140	°F	60	180	R/W
Setpoint 2	16385	16-bit Integer	120	°F	60	180	R/W
Heater Outlet Water	8991	16-bit Integer	N/A	°F	N/A	N/A	RO
Side Arm Tank	9026	16-bit Integer	N/A	°F	N/A	N/A	RO
Alarm Status	9089	Boolean	Off	On/Off	N/A	N/A	RO
Call for Heat	8992	Boolean	Off	On/Off	N/A	N/A	RO

6. START-UP PROCEDURES AND OPERATION

⚠ WARNING!

Always turn off all electrical service to the unit when accessing controls inside the unit enclosure. The enclosure contains high voltage wiring and terminals. If the electrical service is not turned off, and these wires or terminals are touched, a dangerous shock causing personal injury or death. Ensure the enclosure is on the unit before restoring electrical service.

1. Use a multimeter to check resistance to ground between all element terminals and the element mounting flange. *See Page 18.*
 - Fill the heating chamber with water. Open the relief valve to allow air to escape. Be sure all connections into the heating chamber are tight.
 - After turning off all electrical service to the unit, open the enclosure and check inside for leaks while the heating chamber is full of water at water line pressure. Contact customer service if a leak is observed.
 - If leaks are present, tighten down the threaded pipe connections of each heating element. To avoid damaging the pipe threads, do not over tighten.

IMPORTANT

All leaks must be corrected prior to turning on the electricity to avoid damage to components.

2. The heating chamber must be full of water before turning on the electricity. If elements are energized without water in the heating chamber, they will burn out immediately.

IMPORTANT

Dry-starting the unit will void all warranties.

3. Check the tightness on all electrical connections before turning the unit on.
4. Energize the manual disconnect switch. Check for proper voltage (with a voltmeter) on the power circuit. Voltage should not vary more than 5% from voltage shown on data plate. If voltage exceeds these limits, turn off main disconnect and contact utility company.
5. Energize control circuit switch. Check for proper voltage.
6. Check for proper amperage with ammeter on power circuit. Amperage should not vary more than 5%, when under full load, from amperage shown on data plate. See Section 7.
7. Check magnetic contactors for noise. If noisy, i.e., buzzing or chattering, turn off main power disconnect, disassemble contactor and blow out foreign particles. Drill filings, dirt or other particles can cause pitting of points which will in turn burn out the contactor and/or wire. Extra care has been taken during fabrication and inspection for cleanliness, however, field installation is often responsible for debris collecting on the contactor points.
8. The top thermostat is a temperature limiting safety device set at 195°F. The operating thermostat is factory set at 140°F, with a maximum operating setpoint of 180°F.
9. After startup and with the water heater operating, allow the water in the tank to reach the desired temperature and de-energize the heating elements. Draw hot water from a nearby faucet or outlet until the heating elements come back on. This will check for proper operation of the thermostats and other operating controls.

IMPORTANT

After approximately 30 minutes of operation, turn off all power to the unit. With main disconnect off, check each wire connection and fuse clip for elevated temperature. If an elevated temperature is noted, there is a loose connection at the point of greatest heat. All connections must be tight for proper performance.

7. ELEMENT CONTINUITY CHECKS

⚡ ELECTRICAL HAZARD WARNING ⚡

Electrical voltages up to 480 VAC and 24 volts AC may be used in this equipment. The cover on the unit's power box (behind the front panel door) must be installed at all times, except during maintenance.

NOTE: Element wire leads must be disconnected to prevent false OHM readings.

⚠ WARNING!

Always turn off all electrical service to the unit when accessing controls inside the unit enclosure. The enclosure contains high voltage wiring and terminals. If the electrical service is not turned off, and these wires or terminals are touched, a dangerous shock causing personal injury or death. Ensure the enclosure is on the unit before restoring electrical service.

480V/3Ø Units				
INPUT kW	MINIMUM CONTACTOR AMPS (RESISTIVE)	240V/1Ø ELEMENTS	480V/1Ø ELEMENTS	MINIMUM SSR AMPS (RESISTIVE)
12	50	-	(3) x 4kW	40
18	50	-	(3) x 6kW	40
24	50	(6) x 4kW	-	40

30	50	(6) x 5kW	-	40
36	50	(6) x 6kW	-	40
45	65	(6) x 5kW	(3) x 5kW	40
54	75	(6) x 6kW	(3) x 6kW	65

ELEMENT RATING		OHM READING	AMPS PER ELEMENT
kW	VOLT		
3	480	76.8	6.25
4	480	57.6	8.33
5	480	46.1	10.4
6	480	38.4	12.5
3	240	19.2	12.5
4	240	14.4	16.7
5	240	11.5	20.9
6	240	9.6	25.0

CONTACTOR TORQUE REQUIREMENTS		
WIRE SIZE (TWIN FERRULE)	TERMINAL TYPE	IN-LBS
(2) 8 AWG	BOX	40

SSR TORQUE REQUIREMENTS		
WIRE SIZE (SINGLE FERRULE)	TERMINAL TYPE	IN-LBS
8 AWG	BOX	22

8. MAINTENANCE

A preventative maintenance program helps ensure a long trouble-free life of the water heater.

COMPONENT	OPERATION	INTERVAL	REQUIRED
Heating Chamber	Sediment Removal	Every 3 Months	Flushing
Relief Valve	Inspect	Every 6 Months	Test
Electrical Connections	Inspect	Monthly	Inspect for wire discoloration
Electric Elements	Check	Every 6 Months	Amp Draw

8.1. Flushing

1. Turn off the heater main power switch and the heater electrical disconnect switch.
2. Close isolation valves on the inlet and outlet lines to and from the heater.
3. Open the flush ports and allow water to flow until it runs clean.
4. Close the flush ports when finished flushing and reopen isolation valves.
5. Turn the heater electrical disconnect switch to the ON position
6. Turn the heater main power switch to the ON position to return the heater to service.

8.2. Sediment / Lime Scale

Waterborne impurities consist of the particles of soil and sand which settle out and form a layer of sediment on the bottom of the heating chamber and adhere to heat exchange surfaces. The amount of calcium carbonate (lime) released from water is in direct proportion to water temperature and usage. The higher the water temperature or water usage, the more lime

deposits are dropped out of the water. Lime accumulation not only reduces the life of the equipment but also reduces efficiency of the heater.

8.3. Temperature and Pressure Relief Valve

The relief valve should be checked at regular intervals by manually opening the valve but no less than as directed on the instructions attached to the valve. The openings inside the valve may become blocked by a buildup of scale and could become inoperable. If the valve does not open and close properly, and does not blow off internal pressure when tested, **it must be replaced.** Shut down the heater, relieve the internal pressure and replace the relief valve with one meeting the requirements stated on the rating decal located adjacent to the relief valve mounting location.

8.4. Low Water Cutoff

The standard low water control is electronic. Inspection should be made of the electrode on water heaters equipped with electronic low water devices.

8.5. Electrical Connections

Check all electrical connections approximately one to two weeks after the initial start-up to ensure tightness. Heating and cooling occurring during use can loosen connections. Visually inspect wire terminal points for any discoloration on a monthly basis. Discoloration is likely due to a loose connection at the point nearest the discoloration. Check contactors periodically and clean if necessary and repair or replace pitted points caused by foreign particles. Check fuses periodically for continuity and replace if necessary with the same type and rating.

8.6. Electric Element Care

Electric immersion INCOLOY® sheath elements are wound at high wattage ratings and must be completely covered by water while in operation. Otherwise, these parts will overheat and burn out. Scale from the water will collect on the sheathing of the element over a period of time and must be removed periodically to extend the life of the element. Water in some areas will produce the scale buildup more rapidly than other areas. The speed of the scale buildup is also determined by the watt density of the element.

9. TROUBLESHOOTING

IMPORTANT: Disconnect power to the water heater before removing the enclosure cover!

PROBLEM	PROBABLE CAUSE	CORRECTIVE ACTION
Unit does not power on	Main power issue	Ensure main power supply voltage is $\pm 5\%$ of rated voltage. Check breaker and wire size.
No hot water	Thermostat(s)	Check to assure proper thermostat setting.
	Contactors will not pull in	Check continuity between all thermostats or pressure controls. Complete circuit. If one is open, it must be replaced.
	Control circuit switch is in OFF position	Turn switch to ON position.
	Control circuit fuse blown	Isolate cause for failure and replace fuse.
	Low water cutoff closed	Check for open circuit. Check water level in tank. Replace low water cutoff if defective.
	Heating elements	Check wiring between elements.
Insufficient hot	Heater not large enough to satisfy peak	Add booster or additional kw input. Consult local Lync

water	demands	representative.
	Hot water lines not insulated	Add insulation; it will protect against heat loss and save on cost of operation.
	Power fuse(s) blown	Check fuses for continuity. Replace if blown. If blown, determine cause of break before replacing with same type fuse.
	Contactors(s) not closing	Check coil for continuity. If defective, replace.
	Thermostat(s) not correctly set	Check to assure proper thermostat control setting.
	Element(s) not heating	Check for proper amperage draw. Check for proper ohm resistance. Replace if defective. Consult factory.
Burned or discolored wires	Loose connections	Tighten all connections. If charred, replace wire with wire of same type and size.
	Dirty or pitted contactor points	Remove contactor points and inspect. If dirty, clean with emery paper. CAUTION: Point must remain flat. If pitted or burned, contactor points must be replaced.
Blown fuses	Loose connection. Defective element	Check all connections for tightness. Check ohm resistance in electric elements. Replace.
High or low voltage	Local utility	Check with local utility.
High or low amperage	High or low voltage. Defective element	Check with local utility. Low amperage, check fuses, tighten connections. Check ohm resistance on elements.
Display: Red triangle alarm icon and the number 1 are flashing	A low water condition is sensed in the water heater	Ensure that all system valves are open. Bleed air from water system. Once proper water flow is restored, reset the Low Water safety.
	The low water probe wire may be loose	Remove the heater enclosure cover and check wire connection at the probe and the ELWCO board.
	The low water probe may be fouled	Clean or replace the probe
Display: Red triangle alarm icon and the number 2 are flashing	A high temperature limit has been exceeded. 190°F Max	The temperature regulating control or power control device (SSR) is defective.
	The manual reset limit may be defective	If the limit will not reset once the vessel temperature has dropped well below the 190°F setting, it must be replaced.
Display: Red triangle alarm icon and the number 3 are flashing	The SSR power control is indicating a fault.	Check the incoming power for correct voltage a phase balance. Check for element shorts or failures. If an external cause cannot be found, replace the SSR control.
Display: Red triangle alarm icon and the number 4 are flashing	One of the thermistor temperature sensors is defective or a sensor wire is broken	Identify the defective sensor. Enter the TEMP Menu. The defective sensor will display "out of range". Replace defective sensor or repair the wire. <i>Note: The Side Arm Tank sensor will show as "out of range" if the Side Arm mode is not in use.</i>
Display: Red triangle alarm icon and the thermometer icon are flashing	The electronic auto reset high temperature limit has been exceeded	Operating conditions such as return water temperature may exceed recommended limits. The PID parameter settings have been changed and no longer allow for proper temperature control

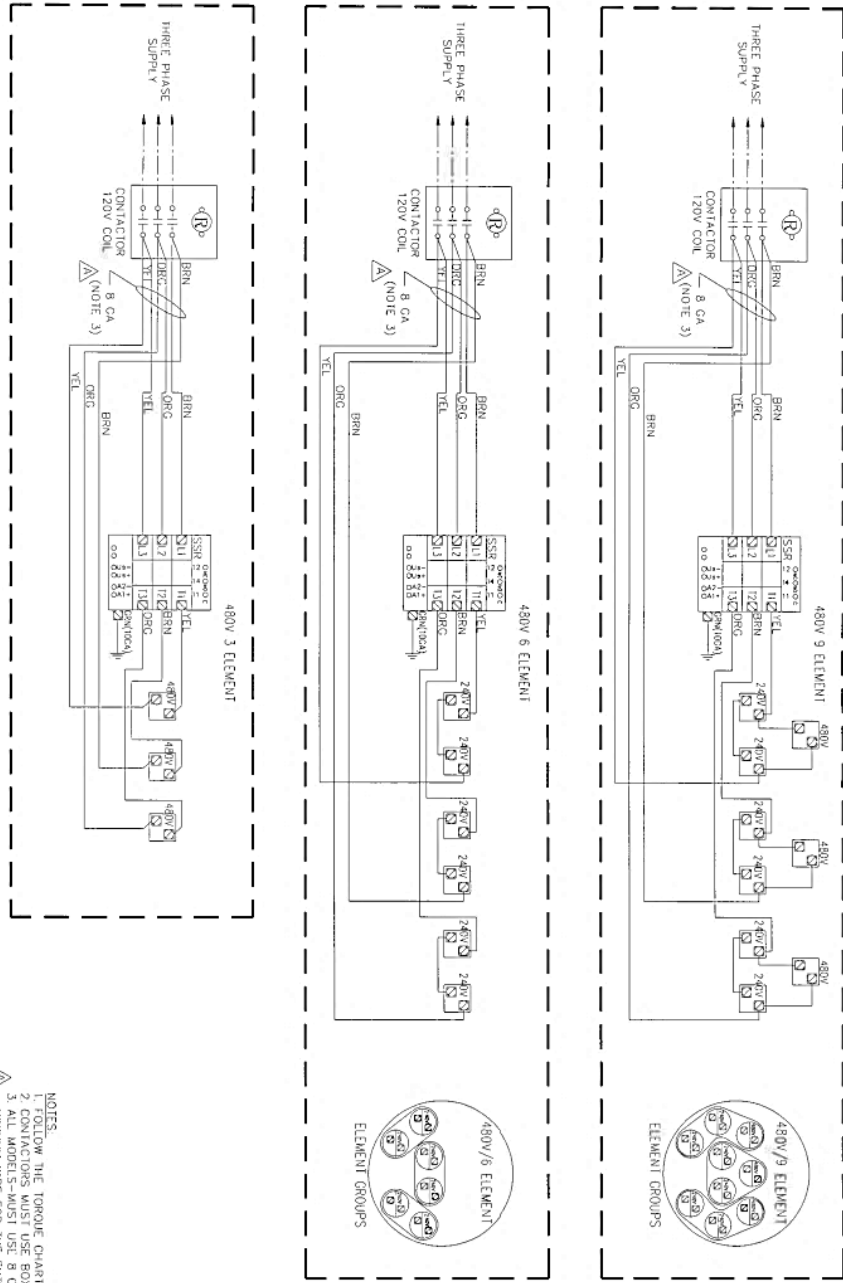

INPUT KW	MIN CONTACTOR AMPS (RESISTIVE)	240V/1Ø ELEMENTS	480V/1Ø ELEMENTS	MIN SSR AMPS (RESISTIVE)
12	40	-	(3) x 4kW	40
18	40	-	(3) x 6kW	40
24	40	(6) x 4kW	-	40
30	40	(6) x 5kW	-	40
36	50	(6) x 6kW	-	40
45	65	(6) x 5kW	(3) x 5kW	40
54	75	(6) x 6kW	(3) x 6kW	40

WIRE SIZE (TWIN FERRULE)	CONTACTOR AMPS (RESISTIVE)	TERMINAL TYPE	IN-LBS
(2) #8	40	BOX	40
(2) #8	50	BOX	40
(2) #8	65	BOX	40
(2) #8	75	BOX	40

WIRE SIZE (SINGLE FERRULE)	SSR AMPS (RESISTIVE)	TERMINAL TYPE	IN-LBS
#8	40	90X	22

USE ONLY CARLO GAVAZZI SSR #RCC3A60D20CGE0F

- NOTES:
- FOLLOW THE TORQUE CHARTS TO MAKE PROPER TORQUED CONNECTIONS.
 - CONNECTIONS MUST BE MADE TO THE TERMINALS LISTED. 600V 100°C INSULATION MODEL MUST USE 8 GA STRANDED WIRE AND 90 OR CSA LISTED 600V 100°C INSULATION.
 - MINIMUM WIRE FOR THE ENTIRE HEATING (ELEMENT) CIRCUIT.
 - USE INSULATED FERRULES ON CONTACTOR AND SSR CONNECTIONS. USE RING TERMINALS (ABB STA-KON ROB-10) OR EQUIVALENT FOR ELEMENT CONNECTIONS.
 - CONTACTORS SIZED ACCORDING TO SQUARE D MODEL D AND ABB MODEL D#RCC3A-1.

11. REPLACEMENT PARTS

ITEM	DESCRIPTION	PN	Notes
1	T&P Relief Valve	106127	
2	Controller	169412	
3	LWCO Test Switch	70573	
4	LWCO Reset Switch	70573	
5	On/Off Switch	162412	

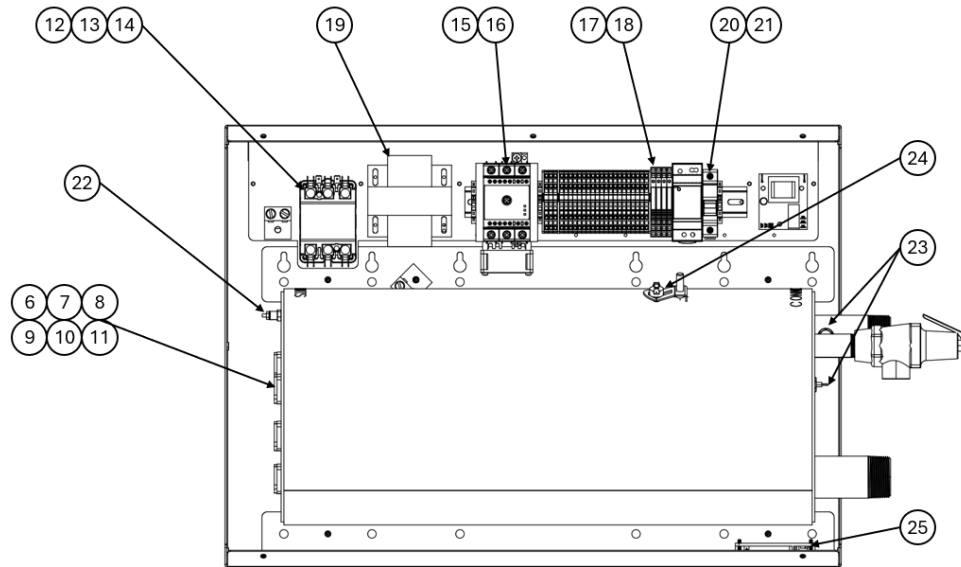

ITEM	DESCRIPTION	PN	Notes
6	Element, 4kW 480V 3 Phase	199085	12 kW input model
7	Element, 5kW 480V 3 Phase	199084	45 kW input
8	Element, 6kW 480V 3 Phase	169232	18, 54 kW inputs
9	Element, 4kW 240V 3 Phase	199082	24 kW input
10	Element, 5kW 240V 3 Phase	199081	30, 45 kW inputs
11	Element, 6kW 240V 3 Phase	169233	36, 54 kW inputs
12	Contactors, 75 Amp Resistive	167527	54 kW input
13	Contactors, 65 Amp Resistive	169420	45 kW input
14	Contactors, 50 Amp Resistive	116601	12 to 36 kW input
15	SSR, 65 Amp	166058	54 kW input
16	SSR, 40 Amp	199116	12 to 45 kW input
17	Relay, 120V Coil	169509	
18	Relay, 24V Coil	169408	
19	Transformer	63076	
20	Control Circuit Fuse Holder	166057	
21	Control Circuit Fuse	169411	
22	Probe, LWCO	58154	
23	Thermistor, Tank Control	169195	
24	Thermostat, Manual Reset High Limit	198899	
25	Cooling Fan	169901	

Information concerning the limited warranty information for this product can be found on the Lync website.